



December 19, 2006

Mr. Darren Blank  
**U. S. Department of Labor**  
Mine Safety and Health Administration  
P. O. Box 18233  
Pittsburgh, Pennsylvania 15236  
e-mail: [blank.Darren@dol.gov](mailto:blank.Darren@dol.gov)

*Re: Contract B2532531-Reply to Review Comments received November 2006*

Dear Mr. Blank:

Pursuant to our telephone conversation, I am submitting a redraft of the report “*Geophysical Void Detection Demonstration Project*” as requested in your letter of October 29, 2006. We have attempted to respond to your comments in the same manner as previously, when the professional review was accomplished in April. We find some redundancy in this set of comments as to issues which were previously addressed after the technical review, with additional emphasis on more explanation. Some of the current comments relate directly to the reading and interpretation of seismograph logs and to the discrimination of channel wave signals in the total wave train recorded by a seismograph. This is a topic that requires in-depth explanation which is beyond the scope of the report. Our report was not meant to be a primer on the reading and interpreting of seismograph geophysical logs, but to demonstrate that the technology is available and can accomplish the task of identifying mine voids. We believe that the demonstration was accomplished.

I will address each of your comments in turn, in accordance with the numbering system you provided.

1. You have asked for the clear definitions in the Glossary for the following terms:

Surface Reflection Seismic Survey - Included in the attached.

Wave Seismics - This term was not used in the previous redraft, and I believe there is no reason to include such a definition in the Glossary.

Demodulate – A definition was included, although it was defined on page 6 of the previous redraft.

Gather - Included in the attached.

Fundamental Mode - Included in the attached.

Normal Mode - Included in the attached.

Higher Order Mode - Included in the attached.

Undo Dispersion - Included under “Dispersion” in the attached.

Automated Surgical Muting - Included in the attached.

5480 Swanton Drive / Lexington, KY 40509 / Tel 859.263.2855 / Fax 859.263.2839

Web Site – <http://www.mma1.com> • E-mail – [lexington@mma1.com](mailto:lexington@mma1.com)

Envelope Traces – Defined in text on Page 14.

Migration - Included in the attached.

Geometry Rotation – The term was only used once in the previous draft, and the term was deleted and replaced with a clear explanation in the text.

Offset - The term was only used once in the previous draft, but is included in the Glossary.

2. The word “of” was inserted.
3. The word “predominantly” was deleted and the text was changed to read “both P-waves and S-Waves”.
4. The correct spelling of “Evision” was made in the Reference Section.
5. The correct reference was made in the Reference Section.
6. The correct reference was inserted in the Reference Section.
7. The reference in Para 3, page 8, to the water filled void was re-written to clarify that a water filled section was surveyed and it was still filled with water upon the subsequent re-opening of the mine.
8. The correct reference was inserted in the Reference Section.
9. The referenced to “surveyed” was rewritten as “surveyed with seismic methods”.
10. The figures and maps were imbedded in the report.
11. The paragraph in question is repeated in Section 5.1, where it properly belongs and the reference here was deleted.
12. The paragraph in question is repeated in Section 5.1, where it properly belongs and the reference here was deleted. Additional explanation of the check for dispersion was discussed in Appendix A, and in Section 5.1, a reference to the Appendix is included. The topic is simply addressed in the report and references are included for the reader who desires a more technical understanding.
13. The definition in the glossary has been changed.
14. The text has been changed.
15. An explanation of the survey line was added in Section 3.2 and a reference to that section was included in Section 5.2.

Mr. Darren Blank

**U.S. Department of Labor**

Mine Safety and Health Administration

December 2006 • Page 3

16. The question underlies a misunderstanding as to the meaning of the presented shadow. The survey clearly showed on 35 different recordings (Gathers), the location of the shadow as shown on Figure 9 and Map 2. Figure 9 and Map 2 represent the composite assembly (stacking) of the 35 different recordings. The interpretation was one made by recognizing the individual Gathers and presenting the data as a single presentation. Individual Gathers were not printed, as the data was all processed digitally into the composite presentation in Figure 9 and Map 2 for ISS Line 1 and in Figure 10 and Map 3 for ISS Line 2.
17. The survey using seismic methods verified the original mine map. No additional work was needed.
18. See the response to question 16.
19. The text was rewritten to remove the ambiguity.
20. The text was revised as suggested.
21. The text was revised as suggested.
22. The Figure was revised as requested, although the markings to a knowledgeable person are obvious.
23. A closer review of Figure 10 indicates the image was incorrect and should have been reversed in the initial draft. This error was not observed. A redrafted version of Figure 10 has been inserted and replaces the prior figure.

We appreciate this opportunity to provide this clarification, although some of the comments cannot be addressed simply in the text, as requested, due to the complex nature of the subject matter. If additional information or explanation is required, please contact us and we will be glad to respond at your convenience.

Respectfully submitted,  
**Marshall Miller & Associates, Inc.**  
*Energy • Environmental • Engineering*

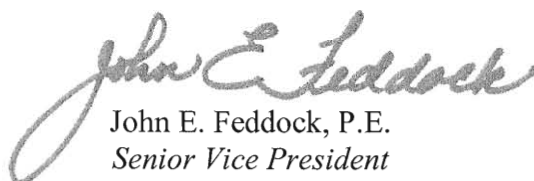
  
John E. Feddock, P.E.  
*Senior Vice President*

JEF/als

c: Scott Keim  
File



# ***Geophysical Void Detection Demonstration Project***

***An Analysis of In-Seam Seismic Reflection Techniques to Identify and  
Locate Abandoned Underground Mine Voids in Advance of Mining***

*December 2006*

Prepared for the  
**U.S. Department of Labor**  
**Mine Safety and Health Administration**  
*Contract No. B2532531*

*Prepared by:*

**MARSHALL MILLER & ASSOCIATES, INC.**

***Energy & Minerals Resources Group***

Route 720, Bluefield Industrial Park  
Bluefield, Virginia 40605  
(276) 322-5467 • FAX (276) 322-3102

5480 Swanton Drive  
Lexington, Kentucky 40509  
(859) 263-2855 • FAX (859) 263-2839

and

**VIRGINIA TECH**

***Department of Geosciences***

4044 Derring Hall (0420)  
Blacksburg, Virginia 24061

---

## COPYRIGHT

---

The Contents of this document are protected by Copyright © to Marshall Miller & Associates, Inc. (*MM&A*) and Virginia Polytechnic Institute and State University (*Virginia Tech*). This report was prepared for the use of the U.S. Department of Labor, Mine Safety and Health Administration (*MSHA*). No part of this publication may be reproduced, stored in a retrieval system, or transmitted in any form or by any means, electronic, mechanical, photocopying, recording, or otherwise, without the prior written permission of MM&A, Virginia Tech, or MSHA.

Information contained in this work has been obtained by MM&A from sources believed to be reliable. However, neither MM&A nor the authors guarantee the accuracy or completeness of any information published herein, and neither MM&A nor its authors shall be responsible for any errors, omissions, or damages arising out of the use of this information. This work is published with the understanding that MM&A and the authors are supplying information.

Any statement or views presented herein are those of MM&A and the authors and are not necessarily those of MSHA. The mention of trade names for commercial products does not imply the approval or endorsement of MM&A, Virginia Tech, or MSHA.

Copyright © 2006 Marshall Miller & Associates, Inc.

Printed in the United States of America

---

## EXECUTIVE SUMMARY

---

It is quite customary for underground coal mining to be conducted in proximity of abandoned underground mines, some of which are prone to accumulate water, methane or other toxic gases, and are often, either poorly mapped, or are without good surface survey control. Mining into such abandoned mine voids poses a great safety risk to personnel, equipment, and production from inundation, or toxic or explosive gas release. Often, surface or underground drilling is employed to detect the mine void and to evaluate the hazards, sometimes with disastrous results. The remote sensing of the mine void is possible through the use of seismic waves emitted within the coal seam. Seismic waves become trapped within a coal seam and their reflection by a coal/water or coal/air interface may be used to detect and locate mine voids. Seismic waves can also be used to locate faults, or abrupt seam truncations, because seismic waves within the coal seam are sensitive to seam perturbations.

**Marshall Miller & Associates, Inc. (MM&A)** and **Virginia Polytechnic Institute and State University (Virginia Tech)**, (collectively, *Researchers*) proposed to test in-seam seismic techniques in the location and definition of abandoned underground mine works. The **U.S. Department of Labor, Mine Safety and Health Administration (MSHA)** awarded *Contract No. B2532531* to the Researchers. The Researchers received the assistance and guidance of the **Virginia Department of Mines, Minerals, and Energy (VDMME)** with regard to the demonstration mine selection and survey control, as well as with activities relating to conducting the experiment. The Researchers then contacted the **Clintwood Elkhorn Mining Company (CEMC)**, a subsidiary of **TECO Energy, Inc. (TECO)**, and requested their participation in the project by providing a demonstration site at their Sassy No. 1 Mine.

The Sassy No. 1 Mine, located near Hurley, Virginia, was idled in December 2002. Conditions for the seismic demonstrations were ideal at this site. Modern mine plans were available. Records indicated the mine contained both water-filled and air-filled voids. Although the demonstrations were not anticipated to require access, TECO and CEMC elected to reopen the mine after the field work was completed.

The Researchers performed two In-Seam Seismic (ISS) reflection surveys, as well as a complementary transmission survey. For the application of an in-seam seismic reflection survey, the Researchers prepared two test sites along the outcrop of the seam, each approximately 1,000 feet in length. An excavated highwall exposed an outcrop free of surface material and weathered coal. The outcrop was in excess of 1,000 feet from the idled underground mine workings of the Sassy No. 1 mine. The first reflection survey was acquired with a short, but relatively linear array of sources and receivers in the vicinity of a water-flooded section of the mine. The second reflection survey was acquired with a longer geophone placement, but crooked source-receiver geometry in the vicinity of both air-filled and water-filled sections of the mine. Subsequently, the Researchers were able to enter the mine and confirm prior mining and conduct a transmission test to confirm in-seam conditions.

Data processing was performed by Virginia Tech under the guidance of Dr. Imhof at the campus facility in Blacksburg, Virginia. After establishing the seismic velocity of the channel wave as a

function of frequency, the Researchers developed a procedure for data processing and generation of images of the mine workings. Using industry-standard seismic data processing packages such as **ProMAX**, the Researchers were able to detect and locate the mine voids with both surveys but with varying degrees of confidence. The report summarizes the surveys, data processing and findings, and outlines the probable limits of the use of in-seam seismic surveys. Although the conclusions indicate that “exploratory” drilling can be replaced by seismic methods, the application of in-seam seismic surveys, in some instances, may not be accurate enough to replace exploration drilling entirely. The Researchers conclude that seismic methods can be used for detection, but if a potential void is detected, focused drilling should be applied for accurate mapping and circumvention of potentially hazardous areas.

John E. Feddock, P.E.  
Charles “Tod” Gresham  
Matthias G. Imhof, Ph. D.  
Daniel Yancey

---

## TABLE OF CONTENTS

---

<b>TITLE PAGE .....</b>	<b>i</b>
<b>COPYRIGHT .....</b>	<b>ii</b>
<b>EXECUTIVE SUMMARY .....</b>	<b>iii</b>
<b>TABLE OF CONTENTS .....</b>	<b>v</b>
<hr/>	
<b>1.0 INTRODUCTION/BACKGROUND .....</b>	<b>1</b>
1.1. Qualifications, Expertise, and Organization.....	2
1.1.1. Marshall Miller & Associates, Inc. ....	2
1.1.2. Virginia Polytechnic Institute and State University.....	4
1.1.3. Background and Expertise of Key Individuals Involved in the Planning, Execution, and Performance of the Demonstration.....	4
1.1.4. Project Organization.....	5
<b>2.0 IN-SEAM SEISMIC SURVEY TECHNOLOGY .....</b>	<b>6</b>
2.1. In-Seam Seismic Methodology.....	6
2.2. Case Studies of Similar Technologies .....	10
<b>3.0 DEMONSTRATION DESCRIPTION .....</b>	<b>11</b>
3.1. Site Description .....	11
3.2. Site Preparation.....	12
3.3. Equipment Setup.....	13
3.4. Explosives.....	14
3.5. Safety Precautions Employed During the Course of the Demonstration .....	16
3.6. Summary of Seismic Reflection Survey.....	16
3.6.1. ISS Line 1.....	16
3.6.2. ISS Line 2.....	17
<b>4.0 SUMMARY OF IN-SEAM TRANSMISSION SURVEY .....</b>	<b>18</b>
4.1. Data Processing: Transmission Survey .....	19
4.2. Results of Transmission Survey .....	21
<b>5.0 DATA PROCESSING FOR ISS SURVEYS .....</b>	<b>21</b>
5.1. Data and Interpretation .....	21
5.2. Results of ISS Line 1 Survey.....	24
5.3. Results of ISS Line 2 Survey.....	26
<b>6.0 OBSERVATIONS .....</b>	<b>28</b>



---

## TABLE OF CONTENTS (CONT.)

---

6.1.	Advantages and Limitations of In-Seam Seismic Technology.....	29
6.1.1.	Detection includes All Subsurface Anomalies.....	29
6.1.2.	Probable Disruption of Normal Mining Activities .....	29
6.1.3.	Special Site Preparation is Required.....	30
6.1.4.	Detection is Independent of Void Material.....	30
6.1.5.	Other Considerations.....	30
6.1.6.	Processing to Allow Widespread Application .....	30
<b>7.0</b>	<b>CONCLUSIONS .....</b>	<b>30</b>
<b>8.0</b>	<b>RECOMMENDATIONS .....</b>	<b>31</b>
<b>9.0</b>	<b>ACKNOWLEDGEMENTS .....</b>	<b>31</b>

### FIGURES

<i>Figure 1: Seam Wave Formation.....</i>	<i>7</i>
<i>Figure 2: Channel Wave Amplitude Characteristics .....</i>	<i>7</i>
<i>Figure 3: Channel Wave Dispersion Characteristics.....</i>	<i>8</i>
<i>Figure 4: In-Seam Mine Void Reflection Characteristics.....</i>	<i>9</i>
<i>Figure 5: In-Seam Seismic Recording Schematic.....</i>	<i>14</i>
<i>Figure 6: Transmission Channel Image .....</i>	<i>20</i>
<i>Figure 7: ISS Line 1 Precondition Image .....</i>	<i>23</i>
<i>Figure 8: ISS Line 1 Envelope Formation Image.....</i>	<i>24</i>
<i>Figure 9: ISS Line 1 Stacked In-Seam Reflection Image .....</i>	<i>26</i>
<i>Figure 10: ISS Line 2 Stacked In-Seam Reflection Image .....</i>	<i>28</i>

### PHOTOGRAPHS

### MAPS

<i>Map 1: Site Layout Map.....</i>	<i>12</i>
<i>Map 2: In-Seam Seismic Projection Line No. 1 Results .....</i>	<i>15</i>
<i>Map 3: In-Seam Seismic Projection Line No. 2 Results .....</i>	<i>15</i>
<i>Map 4: Transmission Test Map .....</i>	<i>18</i>

### GLOSSARY

### REFERENCES

### APPENDIX A DETERMINING AND MODELING COAL CHANNEL WAVE CHARACTERISTICS

### RÉSUMÉS OF AUTHORS

## 1.0 INTRODUCTION/BACKGROUND

Underground coal mining can be a hazardous venture when it is conducted in the vicinity of poorly mapped, abandoned, and/or inaccessible coal mines. The danger of cutting into these abandoned works is well documented. Not only can the ventilation of a mine be compromised in the process, but an inrush of water and/or methane could have devastating, if not fatal, results.

Test drilling ahead of the active faces when the proximity of an abandoned mine is anticipated is the rule. Both State and Federal agencies specify drilling patterns which are designed to maximize the chances of the drill intercepting any such abandoned works. This drilling must be conducted conscientiously in order to gain the intended safety benefits.

Often, neither the coal mine operator nor the regulating agencies can determine with certainty when or where this drilling is to be initiated in order to locate an abandoned or inaccessible mine void. Both the operator and agency have to rely on the mine planning engineer's best judgment on the matter. The engineer, in turn, must exercise his entire investigative and intuitive skills in establishing the point at which test drilling commences.

The engineer has several tools at his disposal which can be used to identify the presence of an abandoned mine. Prior to mining, these tools include a field canvass of the outcrop (if the mine is above drainage), examination of all available mine maps, and/or drilling from the surface on a pattern designed to intercept the abandoned works. Unfortunately, these methods, alone or combined, cannot always effectively define the boundaries of the mine.

Thus, supplementing these tools available to the engineer with geophysical techniques, such as seismic reflection surveys, is in order. Establishing the credibility of seismic techniques has the potential to increase the success and reliability of accurately detecting abandoned and inaccessible underground coal mines.

**Marshall Miller & Associates, Inc. (MM&A)** and **Virginia Polytechnic Institute and State University (Virginia Tech)**, (collectively, *Researchers*) proposed to test in-seam seismic techniques in the location and definition of abandoned underground mine works. The **U.S. Department of Labor, Mine Safety and Health Administration (MSHA)** awarded *Contract No. B2532531* to the Researchers. With the support and guidance of the **Virginia Department of Mines, Minerals, and Energy (VDMME)**, the Researchers were assisted with the demonstration mine selection and survey control, as well as with activities relating to conducting the experiment. The Researchers contacted the **Clintwood Elkhorn Mining Company (CEMC)**, a subsidiary of **TECO Energy, Inc. (TECO)** and requested their participation in the project by providing a demonstration site at their Sassy No. 1 Mine.

The Sassy No. 1 Mine, located near Hurley, Virginia, was idled in December 2002. Conditions for the seismic demonstrations were ideal at this site. Modern mine plans were available. The mine contained both water-filled and air-filled voids. Ventilation could be restarted if the mine needed to be accessed. Although the demonstrations were not anticipated to require access, TECO and CEMC elected to reopen the mine after the field work was completed, and the Researchers were able to enter the mine and confirm mining and in-seam conditions.

## 1.1. Qualifications, Expertise, and Organization

### 1.1.1. Marshall Miller & Associates, Inc.

MM&A is the prime contractor on the proposed project. Founded in 1975, MM&A is a multi-service geological, engineering, and communications firm. With over 190 personnel consisting of mining, environmental, civil, and geotechnical engineers, geologists, and hydrogeologists, MM&A has become one of the most respected geological and engineering consulting firms in the United States. The company has also been working on an international basis since 1986.

The energy and mineral resources staff is among the largest and most experienced in the United States. Over 70 professionals including geologists, hydrogeologists, and mining, civil, environmental, and geotechnical engineers make up the staff, with considerable experience throughout the United States and abroad. Coal, oil, gas, coalbed methane, soils, foundations, hydrogeology, highway construction and precious metals evaluations, as well as experience in mineral exploration and evaluation, have long been provided by the MM&A staff. The majority of MM&A geologists have obtained their Certified Professional Geologist (CPG) affiliation, and many are founding members and officers of professional societies. The engineering staff is comprised of licensed Professional Engineers and Engineers-in-Training with registration in major coal-producing states. The staff has also authored over 200 professional papers, publications, maps, and books.

MM&A's geologists and engineers are the industry leaders in assisting coal operations impacted by unexpected geologic hazards. From the initial underground mapping of the impacted area by certified mine geologists, through development of a predictive geologic model, MM&A provides rapid response to critical productivity interruptions.

A wealth of experience, teamed with strong computer capabilities for use in evaluation of complex geologic data, allows MM&A geologists and engineers to reliably predict the cause and occurrence of hazardous geologic anomalies resulting in interruption of coal seams, unstable roof and floor strata, high-stress areas, faulted or fractured areas, and excessive groundwater inflow. Graphics and 3-D computer simulation modeling are used as a tool to define and present these complexities.

Knowledge of the geologic factors that create hazardous conditions is then used to map the probable occurrence of hazards for the entire reserve area. These predictive maps are an essential tool for optimizing mine plans and developing reliable mine cost forecasting. MM&A provides this service to the majority of coal companies operating in the United States. In addition, MM&A is currently working with **Asian American Coal, Inc. (AACI)** to introduce safe mining practices in the People's Republic of China, based on the prediction of mining hazards in advance of development.

The MM&A work in China includes the application of surface seismic methods to detect potential mining encroachment, the delineation of seam interruptions (faulting and sandstone channels), and the identification of seam continuity. Geophysicists from Virginia Tech are working in conjunction with MM&A on the China evaluation. The same Virginia Tech geophysicists will be an integral part of this proposed MSHA project.

Since its inception in 1975, MM&A has provided surface and subsurface geophysical investigation services to its clients and other consultants. The company promotes the application of geophysics to mining, environmental, hydrogeologic, and geotechnical projects as a cost-effective method for establishing insight to initial phase site planning. MM&A personnel have extensive geological and geophysical experience and can provide assistance in determining the most cost efficient geophysical method to be employed.

MM&A can provide clients with a variety of surface geophysical investigation methods, including:

- Electromagnetic Methods
- Gravity Surveys
- Ground Penetrating Radar
- Magnetometry
- Resistivity Methods

MM&A employs multiple distinguished mining professionals with a wealth of industry experience; some of this previous employment experience is summarized as follows:

- Two Island Creek Corporation Vice Presidents of Engineering
- President and General Manager of Catenary Coal Company (Arch Coal)
- President of Doverspike Coal Company and Ridgeway Fuel Corporation
- Cyprus Amax Coal Company Manager of Engineering
- Peabody Energy Mine Superintendent and Engineering Director
- CONSOL Energy Virginia Division Geologist
- Division Mining Geologist Island Creek Coal Corporation
- U.S. Steel Chief Engineer
- Island Creek Corporation Manager of Construction and Occidental Petroleum  
Manager of Coal Research

Numerous geologists, mining engineers, and civil engineers, all with professional certifications and 10- to 20-plus years of consulting experience, supplement the above-mentioned staff.

MM&A works for mining companies, governmental agencies, financial institutions, and international firms, providing mining expertise on a daily basis.

### 1.1.2. Virginia Polytechnic Institute and State University

Virginia Tech partnered with MM&A and is an integral participant in the demonstration project. MM&A and Virginia Tech have an established history of working on seismic projects on an international basis. Dr. Matthias G. Imhof, Associate Professor of Exploration Geophysics, fills the vital role of geophysicist. Dr. Imhof is a noted expert in the theory and application of wave propagation in complex media and has ample experience in seismic data acquisition and processing.

Dr. Imhof's coal related experience includes the use of seismic technologies to detect mine voids, structural complexities (faulting), stratigraphic features, and seam continuity. In addition, he has authored/coauthored 15 professional publications. Dr. Imhof earned his Ph.D. from the Massachusetts Institute of Technology in Geophysics in 1996.

Dr. Imhof utilized Virginia Tech's geophysical processing hardware and software for data processing and interpretation. Virginia Tech used the most advanced geophysical processing and interpretation software and hardware available, including **Landmark's** industry-standard seismic data processing system **ProMax**. Virginia Tech owns a 60-channel seismic recording system with 10 and 100 Hz phones and has established a good working relationship with **Geometrics**, a manufacturer of seismic recording equipment. Additionally, Dr. Imhof worked with the MM&A team in the set up and collection of all seismic field data.

### 1.1.3. Background and Expertise of Key Individuals Involved in the Planning, Execution, and Performance of the Demonstration

The résumés of the following key MM&A and Virginia Tech participants are attached.

- Marshall Miller & Associates, Inc.
  - John E. Feddock, P.E.
  - Charles "Tod" Gresham
- Virginia Polytechnic Institute and State University
  - Dr. Matthias G. Imhof
  - Daniel Yancey

### 1.1.4. Project Organization

Job Title	Personnel	Company	Responsibilities
Project Administrator	John E. Feddock, P.E.	MM&A	Responsible for the administrative and supervision of the project staff.
Field Coordination	Charles 'Tod' Gresham	MM&A	Responsible for the scheduling and implementation of various task required by the project.
	Mike Willis	VDMME	Assist with the field coordination as required.
Geophysics	Matthias G. Imhof, Ph.D.	VIRGINIA TECH	Responsible for the implementation and data collection of the seismic demonstration(s).
Data Processing	Daniel Yancey	VIRGINIA TECH	Responsible for processing of collected data.
Technical Evaluation Team	Hans E. Naumann, Jr, P.E.	MM&A	Responsible for assembly of all collected data and for interpretation for final report of the demonstration(s).
	John E. Feddock, P.E., P.S.	MM&A	
	Michael G. McClure, C.P.G.	MM&A	
	Matthias G. Imhof, Ph.D.	VIRGINIA TECH	

## 2.0 IN-SEAM SEISMIC SURVEY TECHNOLOGY

The primary technology to locate and delineate abandoned underground mine workings in this demonstration project is an in-seam “seismic survey”. Seismic waves, when trapped in a coal seam by natural seam conditions, are sensitive to in-seam perturbations, such as voids, faults, and abrupt thickness changes. These seismic wave perturbations can be used to further mine planning by detecting voids and other conditions that may impact coal mining and mine planning.

Traditional surface reflection seismic surveys can be applied to underground void detection with the benefit of not disrupting normal underground mining activities because the seismic source and receivers are located at the surface. However, the purpose of the study was to demonstrate the precision and accuracy of in-seam seismic survey technology. The in-seam seismic data are considered superior to surface seismic surveys or other surface survey methods for void detection because in-seam data are independent of surface conditions and directly target hazards of interest in the coal seam.

### 2.1 In-Seam Seismic Methodology

Coal is a soft, low-density material which is sandwiched between harder and denser materials, such as shale or sandstones. The speed of seismic waves in coal may vary, but is typically around 2 kilometer per second (*km/s*) for compressional or P-waves, and 1 *km/s* for shear or S-waves. The over and underlying rocks may have seismic velocities more than twice that of the coal seam. In such cases, the acoustic impedance contrast (product of seismic velocity and density) at a coal seam boundary can exceed 4 to 1.

If a point source, such as a small explosive charge, is located in a coal seam, the seam will act as a dispersive acoustic duct.<sup>1,2</sup> Waves generated by the source will be partially reflected at the upper and lower boundaries of the seam, and energy will be propagated along the seam as the wave bounces back and forth. For initial ray paths that are near vertical, the reflection is sub-critical and some energy is transmitted through the boundary as the wave propagates through the seam. These refractions form so-called “leaky modes.” For more horizontal initial ray paths, the critical angle is exceeded, and total internal reflection occurs without transferring energy into the country rock. These waves are termed “normal modes,” “seam waves,” or “channel waves.” “Channel waves” will be used for consistency purposes in this document. In addition to leaky and normal modes, critically refracted head waves also occur, but they carry very little energy. See *Figures 1 and 2* below.

---

<sup>1</sup> F.F. Evison. A Coal Seam as a Guide for Seismic Energy. *Nature*. 176: 1224-1225.

<sup>2</sup> T.C. Krey. Channel Waves as a Tool of Applied Geophysics in Coal Mining. *Geophysics*. 28:701-714.

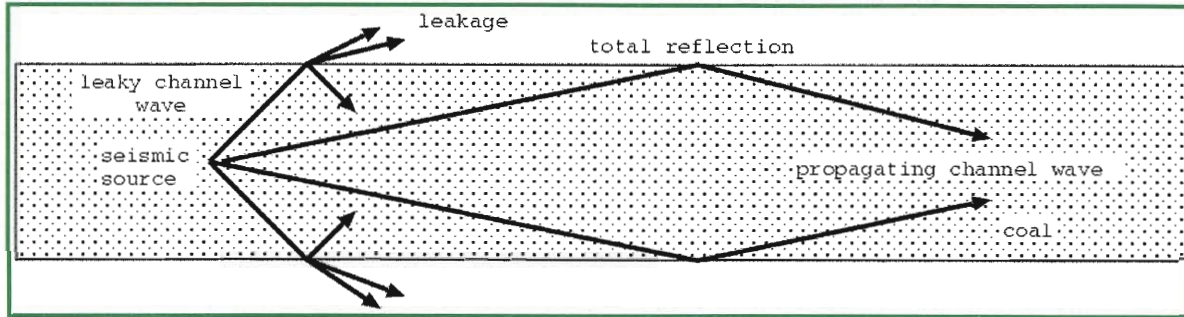

**FIGURE 1: SEAM WAVE FORMATION**

Seismic sources in coal seams: Seismic energy within a coal seam is partially reflected back into the seam and partially transmitted into the surrounding country rock. The reflected portion will be partitioned again and again at the opposing interface, the seismic wave will slowly transfer its energy to the waves transmitted into the country rock. Waves emanated nearly horizontal, however, undergo total reflection without transferring wave energy into the country rock and are trapped in the coal layer as seam or channel waves. (Dombrowski et al., 1994)

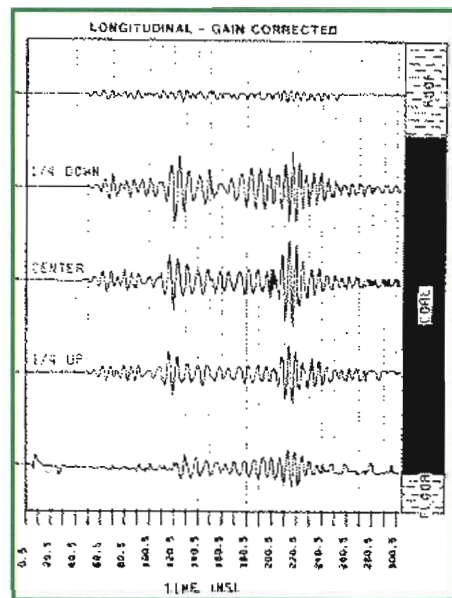

**FIGURE 2: CHANNEL WAVE AMPLITUDE CHARACTERISTICS**

Channel waves have large amplitudes inside the seam, but decay rapidly in the floor and roof.<sup>3</sup>

<sup>3</sup> J. Regueiro S. Seam Waves: What are They? Part 1. *The Leading Edge*, 09(04):19-23, 1990.



Channel waves can be either 1) SH (or Love) waves with their plane of polarization (particle movement) horizontally transversal to their direction of propagation, or 2) P- and SV-waves combined into a Rayleigh-like channel wave with an elliptical particle motion in the vertical plane. An explosive source in the seam generates P-waves and S-waves, but after a short propagation distance these waves convert into Rayleigh-like (P+SV) channel waves because the boundary conditions do not permit separate P- and SV-channel waves.

Channel waves are dispersive. The different frequencies generated by the source propagate with different speeds through the seam. As a result, the initially highly-peaked signal broadens into a long train of waves. Dispersion implies frequency-dependent attenuation (or loss of wave energy). See *Figure 3*.

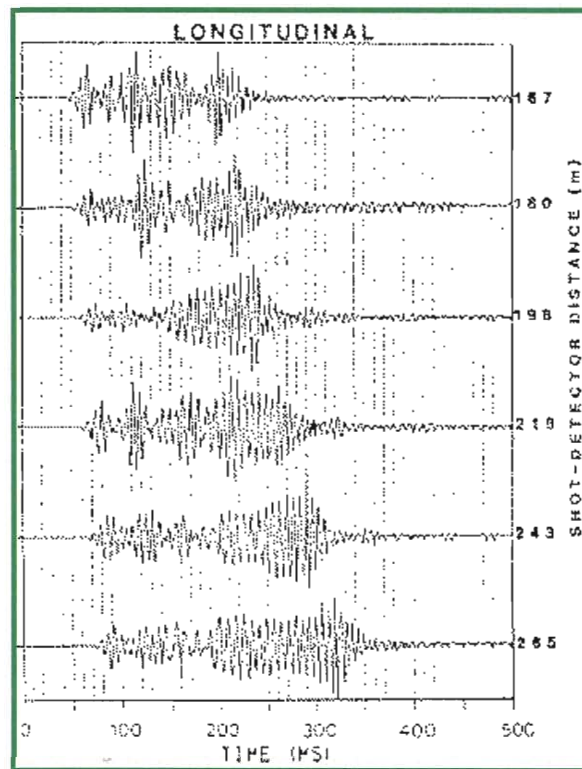
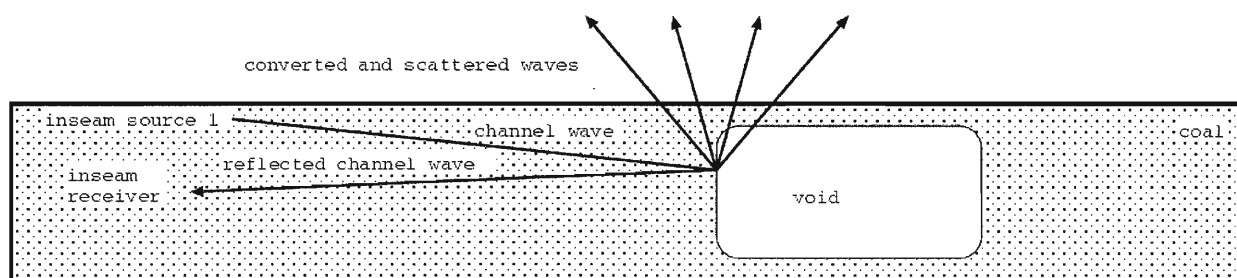

**FIGURE 3: CHANNEL WAVE DISPERSION CHARACTERISTICS**

Channel waves are dispersive. The wave train lengthens with increasing propagation distance because the different frequency components propagate with different speeds.<sup>4</sup>

<sup>4</sup> J. Regueiro S. Seam Waves: What are They? Part 1. *The Leading Edge*, 09(04):19-23, 1990.

While a channel wave is trapped in a coal seam, any change to the waveguide causes a reflection of the channel wave and conversion to body waves propagating in the country rock. The original channel waves might creep around the disturbance and continue propagation as a channel wave, albeit with diminished amplitudes and with delayed arrivals. A mined-out void in the seam, however, will block the continued passage of channel waves very effectively. The energy of the original channel wave is mostly reflected with some scattering transfer to body waves propagating into the country rock. See *Figure 4*.



**FIGURE 4: IN-SEAM MINE VOID REFLECTION CHARACTERISTICS**

The non-leaky channel (seam) wave propagates in the seam until it hits a discontinuity such as a mine void or a fault. The channel wave is reflected back towards the receivers located at the seam face. The initial channel wave, however, is also partially scattered by the void.

The data processing sequence for in-seam seismic data is less developed than for reflection surface seismic data. Several major experiments to use channel waves were conducted in the 1970s and 80s, but very little work appears to have been performed in the last 20 years. One problem with in-seam seismic data is the dispersive nature of channel waves. As the seismograph records the full wave train arriving at the receiver, detection and sorting of the channel wave is done digitally by isolating the apparent frequency, sensing and isolating phase relationships, and recognizing relative time frames. In theory, each frequency should be processed and imaged separately. In practice, the received signals are compressed to undo dispersion<sup>5</sup>, and filtered with a narrow bandpass (demodulated) to one pulse of lower frequency. The purpose of the remaining data processing is imaging, i.e., to locate the origin of the signal. This reflection origin may be a void, a fault, or another seam distortion. Two different techniques were used to image in-seam reflection seismic data. One method is an approximation of travel-time migration often termed lag summation, which is based on the Kirchhoff-Huygens approach to diffraction theory, and is called Adaptive Lag Sums (*ALS*). The other is a modification of Common-Depth Point (*CDP*) stacking routinely used to process surface seismic data, and is termed Dynamic Trace Gathering (*DTG*). In the meantime, methods for PreStack Depth Migration (*PSDM*) have been developed and are now routinely applied to surface seismic data. PSDM rendered both ALS and DTG obsolete.

<sup>5</sup> I. M. Mason, D. J. Buchanan, and A. K. Booer. Channel Wave Mapping of Coal Seams in the United Kingdom. *Geophysics*, 45(07):1131-1143, 1980.

The determining and modeling of coal channel wave characteristics has been demonstrated in theory as well as in practice. See *Appendix A* for a more thorough discussion on channel wave characteristics.

## 2.2. Case Studies of Similar Technologies

The use of in-seam seismic surveys was demonstrated in a study by Buchanan et al.<sup>6</sup> who applied reflection and transmission in-seam seismic data to detect faults cutting through coal seams. These researchers were able to identify the faults by locating the transmission sources, with sources in one roadway and receivers in the other. The locations were identified using ALS and DTG.

The second example is a study by Mason et al.<sup>7</sup> who applied reflection in-seam seismic data to image a roadway and a fault cutting through the coal seam. Again, the study was conducted between two parallel roadways separated by 223 meters (725 ft). One roadway was used to site one seismic source and six receivers, while the other roadway was used as a reflector.

The third example from Hanson et al.<sup>8</sup> combined the ALS and DTG approaches into a holistic migration algorithm.<sup>9</sup> For every point of the image, a discrete value was calculated by stacking all seismic waveforms, with each wave form migrated in time proportionally to the total distance from the source to the image point and to the receiver. Hanson et al.<sup>10</sup> found that the resolution of the image was inversely proportional to the distance from the array and directly proportional to the shortest detectable wave length (or the highest useful frequency). The absolute error of distance measurement is determined by the accuracy of the velocity model used for the reconstruction of reflectors. The velocity model can be improved using transmission travel time measurements or travel time tomography. They stated that a reasonably precise location of receivers and sources was required to ensure accurate images. Lastly, they observed that channel waves were more sensitive to voids in coal seams than waves propagating in the adjacent country rock.

---

<sup>6</sup> D. J. Buchanan, R. Davis, P. J. Jackson, and P. M. Taylor. Fault Location by Channel Wave Seismology in United Kingdom Coal Seams. *Geophysics*, 46(07):994-1002, 1981.

<sup>7</sup> I. M. Mason, D. J. Buchanan, and A. K. Boer. Channel Wave Mapping of Coal Seams in the United Kingdom. *Geophysics*, 45(07):1131-1143, 1980.

<sup>8</sup> D. R. Hanson, T. L. Vandergrist, M. J. DeMarco, and K. Hanna. Advanced Techniques in Site Characterization and Mining Hazard Detection for the Underground Coal Industry. *Int. J. Coal Geol.*, 50:275-301, 2002.

<sup>9</sup> E. A. Robinson. Acquisition/processing - Further to Norman Neidell's series... Holistic Migration. *The Leading Edge*, 17(03):313-320, 1998.

<sup>10</sup> D. R. Hanson, T. L. Vandergrist, M. J. DeMarco, and K. Hanna. Advanced Techniques in Site Characterization and Mining Hazard Detection for the Underground Coal Industry. *Int. J. Coal Geol.*, 50:275-301, 2002.

### 3.0 DEMONSTRATION DESCRIPTION

The in-seam method for void detection was demonstrated with a currently non-operational coal mine (with accurate and recent surveys), that could be re-ventilated and entered if necessary. The mine was partially flooded, which allowed for performing one seismic experiment at the air-filled part, and a second one at the flooded part. The demonstration was not performed in the mine, but rather from the seam outcrop at the surface, allowing for ease of seam access, site preparation, safety concerns, and cost control. Moreover, personnel and visitors without certifications could observe the demonstration with only on-site safety training.

#### 3.1. Site Description

The mine is owned by CEMC, a subsidiary of TECO, and is located near Hurley, Virginia. The mine is permitted as Sassy No. 1 Mine and mines the Splashdam seam. The proposed demonstration site is located at Latitude 38° 28' 10" and Longitude 82° 2' 9". The company began mining operations on November 10, 2001, and ceased operations in December 2002. The Splashdam seam at the portal is at an elevation of 1,110 feet above sea level (ASL) with the seam dipping to the northwest, consistent with the mine development. The seam elevation at the extent of mining is 1,030 feet ASL.

The Splashdam seam is 30 inches thick with a 1-inch parting in the middle of the seam. The roof is generally shale and clay that is 13 inches thick and the floor is shale and clay. As noted above, the mine dips to the northwest. Based on inspections at the time the mine was idled and upon re-opening of the mine after completion of the demonstration project field work, the extreme northwest portion of the mine was filled with water.

Mine ventilation equipment and electric power were available at this site. Access to the mine is via paved secondary roads, with limited housing proximal to the mine and the demonstration site. Two portions of the mine were surveyed using seismic techniques during the demonstration project: the northwest section with water-filled voids and the eastern portion of the mine, no closer than 600 feet from the portal entries, with air-filled voids. An outcrop of the Splashdam coal seam is visible at the mine entrance. See *Map 1*.

## MAP 1: SITE LAYOUT

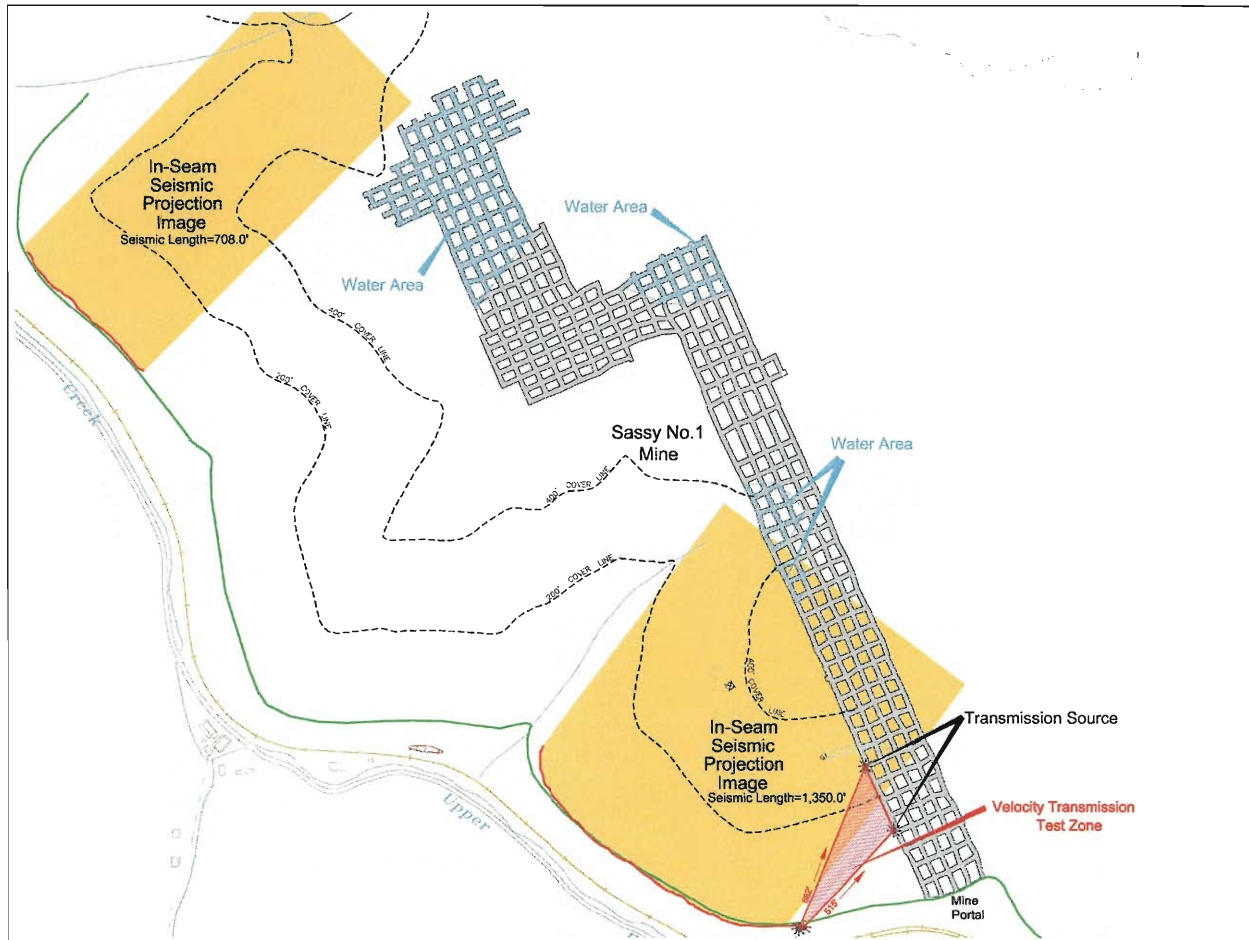

### 3.2. Site Preparation

Initially, the surface of the site was surveyed to establish control and to determine the existing topography and the probable location of the seam outcrop. The existing seam outcrop and bench were cleared of trees and brush to allow for unrestricted access and placement of the seismic equipment. Utilizing a track dozer, the seam crop was cut back to an area free of weathered coal to a bench width that would allow adequate space for transport and placement of equipment. Two sections of outcrop were exposed, each approximately 274 m (900 ft) in length. During the preparation of ISS Line I, a seam roll (a localized drop and then increase in elevation over a short distance) was encountered on the eastern end of the proposed location. Consequently, ISS Line 1 was shifted to the northwest to avoid the local geologic condition. The seam along each ISS line was marked manually for the placement of the geophones in the seam and the drilling of 1.0 m (3 ft) holes for the explosive charges as the seismic source. Upon completion of the seismic survey, the holes and geophones were surveyed using laser-based surveying instruments to obtain accurate locations. As required, proper storm water run-off controls were provided, consisting of, but not limited to, check dams and silt fences. At the conclusion of the seismic surveys, regrading and seeding of the disturbed area were completed.

### 3.3. Equipment Setup

The Researchers performed the study at the two different locations; near the water-filled mine works and then near the air-filled mine works. In either case, 60 geophones were placed on an approximate even spacing along the prepared coal seam outcrop to form a geophone array. The geophones were inserted horizontally into the middle of the seam. Vertical geophones (100 Hz) were used, but mounted perpendicular to the face of the seam outcrop by drilling a hole into the seam and driving the geophone spike into it with a rubber hammer. Seismic sources consisted of explosive charges placed in boreholes drilled 90 degrees to the crop, each approximately 1.0 m (3 feet) deep and approximately midway between pairs of geophones. Upon detonation of the explosive charge, channel waves propagated into the seam until their propagation was blocked by the mine voids, and the channel waves were reflected back to the outcrop.

The equipment used in this demonstration has a proven track record for dependability and ruggedness and can withstand harsh field conditions typically found in the mining industry. This equipment is often used in petroleum exploration, mining, and environmental surveys and is shown below:

#### Seismic Detection and Recording Instruments



- **Geometrics StratView** seismographs utilize specialized digital signal processors to perform filtering and correlation in a fraction of the time required by Pentium type processors. The **StratView** seismograph acquires up to 60 data channels simultaneously.

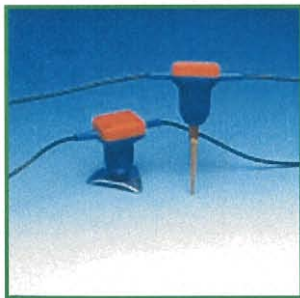

- **The Geophones** are manufactured by **Sercel**. The unit selected is the broadband model L-100, used for high resolution surveys at frequencies exceeding 100Hz. 100Hz geophones have springs stiff enough to be used in vertical or horizontal orientation.

The centerpiece of the seismic acquisition system is the seismograph, which is a personal computer with an analog digital converter and other electronic components. The seismograph is powered by a 12-volt car battery or a 110-volt AC to 12-volt DC converter. Up to 60 geophones (mechanical microphones) are attached to the seismograph via a geophone cable. The start of the seismic event is triggered by the blast control box which is connected to the seismograph via the trigger cable. A schematic of the acquisition system is shown in *Figure 5*.

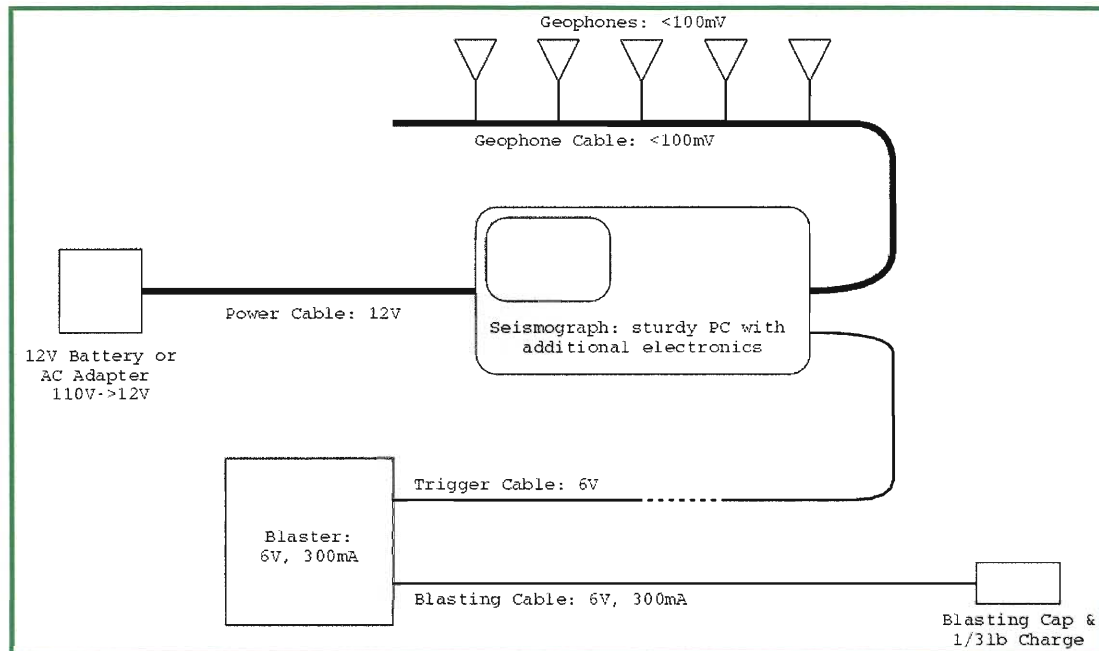

**FIGURE 5: IN-SEAM SEISMIC SCHEMATIC**

Schematic of the seismic acquisition system.

At present, these systems are not approved by MSHA for use in underground operations. In fact, currently no seismic equipment appears to have been approved by MSHA for use in underground coal mines.

### 3.4. Explosives

Since a blasting charge was used to generate the acoustic wave in the seam, 30 CFR, Subpart E-Explosives applied to this demonstration. A blaster, certified by the state of Virginia, was used to place and detonate the charges. Prior to initiation of work, copies of the blasting technician's licenses and certifications were verified. For the seismic sources, the Researchers used explosive charges of 0.11 kg (1/4 lb) placed in holes drilled 1 to 1.5 m (3-5 ft) into the seam. The holes were drilled far enough to prevent fracturing or cracking of the face. After placing the charge, each hole was carefully tamped with gravel to maximize seismic energy. Each explosive charge consisted of a 32mm x 102mm (1¼ in x 4 in) permissible emulsion explosive with a high detonation velocity. The explosive was initiated by a "0" millisecond (ms) delay blasting cap by **Dyno Nobel, ASA** (detonator CD-225, REO, 225 volts). *Maps 2 and 3* show the locations of the source boreholes and the geophone receivers.

### MAP 2: IN-SEAM SEISMIC PROJECTION LINE NO. 1 RESULTS

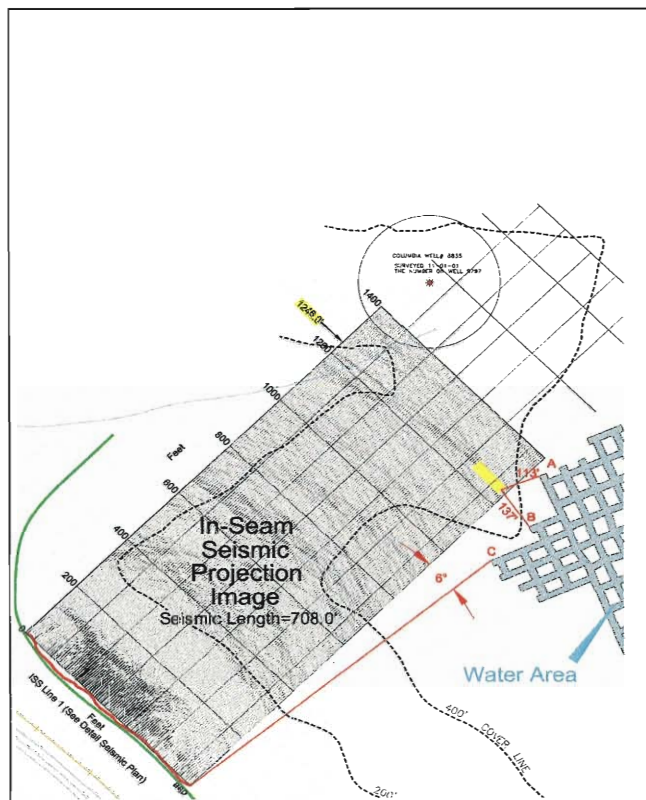

### MAP 3: IN-SEAM SEISMIC PROJECTION LINE NO. 2 RESULTS





### 3.5. Safety Precautions Employed During the Course of the Demonstration

All codes, both State and Federal, were strictly adhered to in performance of the demonstration. Prior to entering the mine surface area, the Owner, TECO, provided hazard training to all personnel, per 30 CFR Part 48 §48.31-Hazard Training and MSHA Rules and Regulations. Additionally, those personnel on site had certification meeting the criteria for Certified Training and Retraining, as referenced in Subpart B-Training and Retraining of miners working at surface mines and surface areas of underground mines. Although not anticipated, the availability of the mine allowed demonstration project personnel to enter the mine, only after the requisite training and in the company of a certified and qualified miner provided by the mine Owner. In case of emergencies, first-aid materials were on site and accessible to all personnel.

### 3.6. Summary of Seismic Reflection Survey

In February, 2005, MM&A and Virginia Tech conducted the seismic survey at the Sassy No. 1 Mine near Hurley, Virginia. The survey was performed in accordance with the procedures, but the actual survey line had to be adjusted for access and topographic changes that were not evident on the available topographic mapping. ISS Line 1 is located near the water-filled section of the mine, while ISS Line 2 is near the air-filled section (See *Maps 2 and 3*).

#### 3.6.1. ISS Line 1

The reflection survey for Line 1 was obtained from a receiver array consisting of 60 geophones spaced at approximately 3.6 m (12 ft). Explosive charges were used as seismic sources. The charges were grouped in pairs, each pair was approximately 3.6 m (12 ft) apart and there was a spacing of 7.2 m (24 ft) between pairs. There were 37 explosive charges detonated, but only 35 provided usable recordings. The charge in Hole No. 1-54B was used as a background noise test, and the second charge in Hole No. 1-666B was a misfire. At this location, the mine was expected to be 370 m (1,213 ft) away. The sample rate on the geophones was 0.25 ms, and the total record length was 5.0 seconds. The following table lists the survey parameters for the Line 1 reflection survey.

Description	Parameter
Sources	37
Source Spacing	3.6 m (12 ft)/7.2 m (24 ft)
Usable Sources	35
Geophones	60
Geophone Spacing	3.6 m (12 ft)
Source Line Length	197 m (646 ft)
Geophone Line Length	216 m (708 ft)
Source Hole Depth	1 m (3.28 ft)
Nominal Target Distance	370 m (1200 ft)

### 3.6.2. ISS Line 2

The reflection survey for Line 2 is near the air-filled section of the mine at an estimated distance of 240 m (787 ft) from the void target. Along Line 2, the geophone and seismic source spacing were arranged differently than Line 1. Seismic source holes were spaced on approximately 9.1 m (30 ft) centers. Geophones were arranged approximately 2.14 m (7 ft) on either side of a seismic source hole. The receiver array, consisting of 60 geophones, was spaced on alternate centers of approximately 4.27 m (14 ft), and approximately 4.88 m (16 ft). Explosive charges as described above were used as seismic sources. There were 46 explosive charges detonated, spaced at 9.1 m (30 ft) apart along a line 1,350 feet in length. The geophones extended from Hole No. 2-203G, near the charge in Hole No. 2-210B, to Hole No. 2-1087G, near the charge in Hole No. 2-1080B. Of the 46 charges, only 37 provided usable recordings. The charge in Hole No. 2-0B was used as a background noise test, and the charges in Hole Nos. 2-30B, 2-60B, 2-90B, 2-120B, 2-240B, 2-270B, 2-300B, 2-1050, and 2-1080 did not trigger due to cable sensitivity problems. The sample rate on the geophones was 0.25 ms, and the total record length was 5.0 seconds.

The loss of 8 sources on the western side of the survey line created a situation where there were fewer reflection data survey points on the western side of the survey as opposed to the eastern side of the survey line. Although the reflection density will be much greater between geophones placed between Hole Nos. 2-653G and 2-1087G, the number of seismic sources was still high enough for the geophone spacing to give sufficient information between holes 2-223G and 2-653 G for a precise void location.

Description	Parameter
Sources	47
Source Spacing	9.1 m (30 ft)
Usable Sources	37
Geophones	60
Geophone Spacing	4.27 m (14 ft)/4.87 m (16 ft)
Source Line Length	421 m (1380 ft)
Geophone Line Length	270 m (884 ft)
Source Hole Depth	1 m (3.28 ft)
Nominal Target Distance	240 m (800 ft)

#### 4.0 SUMMARY OF IN-SEAM TRANSMISSION SURVEY

The purpose of the transmission survey was to accurately measure the velocity of channel waves in the coal seam. The Researchers were given access to the mine, which enabled a direct transmission test from the mine to the outcrop. The transmission survey consisted of a geophone array at the outcrop recording from two different seismic source sites in the mine. The geophone array along the outcrop consisted of a 6.4 m (21 ft) receiver array with 30 geophones. The geophones were arranged in two staggered rows in the middle third of the coal seam approximately .45 m (1.48 ft) apart and with .22m (.72 ft) between each geophone in a row. The Researchers used 100Hz vertical geophones, but mounted them perpendicular to the face of the seam outcrop by drilling a 6 mm (1/4 in.) hole into the seam and driving the geophone spike into it with a rubber hammer. For seismic sources in the mine, the Researchers asked the mine foreman to use a sledgehammer to strike a railroad spike placed in the seam inside the mine at distances of 157 m (515 ft) and 208 m (682 ft) from the receiver array as show in *Map 4*. To improve the signal to noise ratio, the foreman struck the spike ten times at each location recording each strike separately.

MAP 4: TRANSMISSION TEST MAP

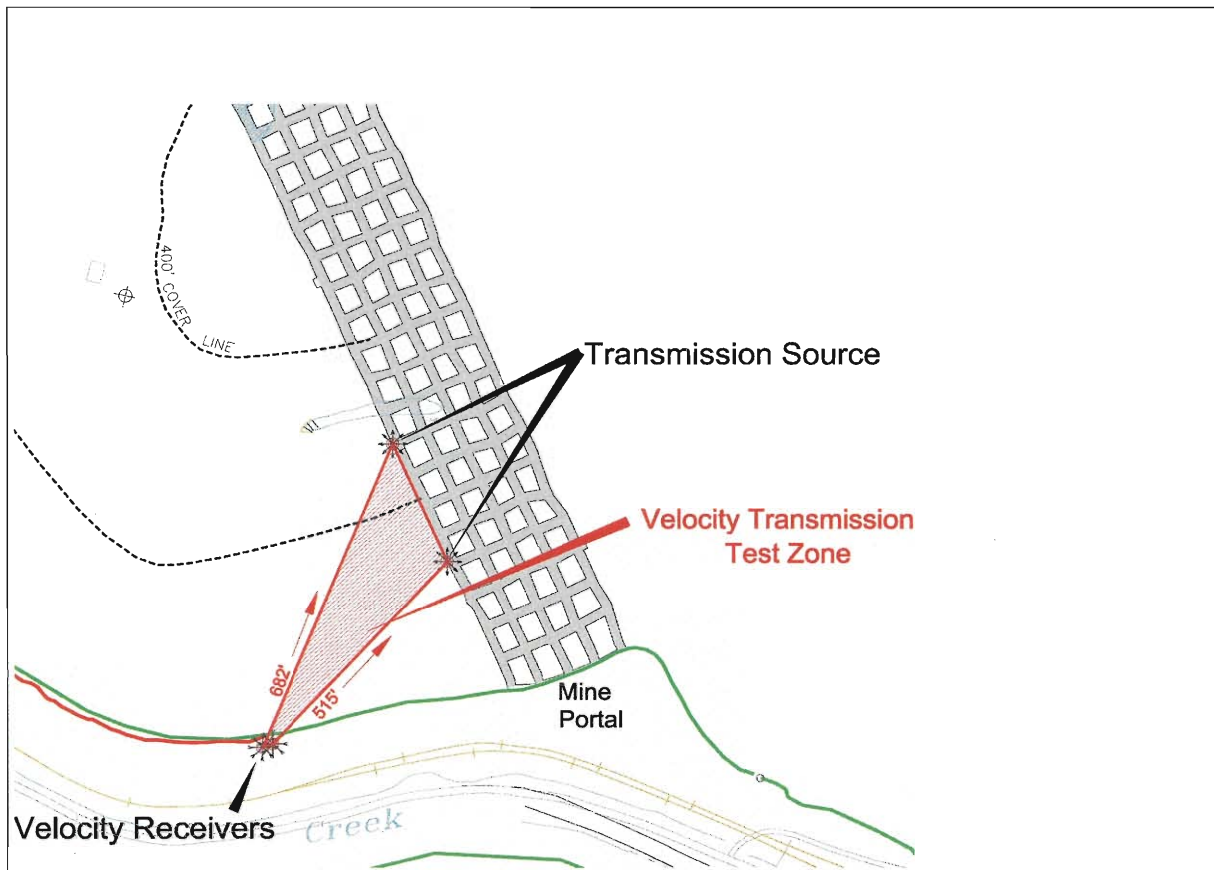

#### 4.1. Data Processing: Transmission Survey

The primary difficulties encountered with in-seam surveys are channel wave velocities and their dispersion characteristics. The Researchers analyzed the transmission data to estimate the velocity of the channel waves. The Researchers applied predictive deconvolution with a lag of 16.6 ms to remove pervasive 60 Hz powerline noise. After bandpass filtering (10-100 and 750-1000 Hz) which passed frequencies between 100 and 750 Hz but removed anything lower than 10 Hz or higher than 1000 Hz, the Researchers stacked the gathers of each source point to increase the signal to noise ratio. *Figure 6* shows the stacked gather for the 210 feet source distance. The Researchers not only observed the beautifully dispersed wave train of the fundamental mode, but also late-arriving events corresponding to higher order modes. The fundamental mode arrives at approximately 0.452 seconds, while higher modes are observed near 0.50 and 0.52 seconds. The fundamental mode has the largest amplitude and may be the most useful arrival for imaging purposes.

#### 4.2. Results of Transmission Survey

The Researchers determined the velocity of the fundamental mode to be about 460 m/s (1,510 ft/s). A transmission survey is needed for accurate location unless a reliable estimate of the channel wave speed can be obtained beforehand. The transmission survey can have source and receiver geometries consisting of face-outcrop, face-borehole, or borehole-borehole. The distance between source and receiver should be large enough to provide not only a reliable velocity estimate, but also to allow for the development of the dispersed wavetrain. This distance is estimated to be 150 m (500 ft) or more. The identification of the channel wave presents no significant challenge as they are characterized by dispersed wavetrains that are easy to identify on seismic data as per *Figure 6*. The Researchers chose the first time response for interpretation of subsequent data. The initial arrival time of the channel wave was 452 ms and spanned 22 ms for the 208m (682 ft) transmission survey test. The median arrival time and the maximum arrival time will give much slower channel wave velocities, approximately 1,440 ft/s or 4.6 percent slower.

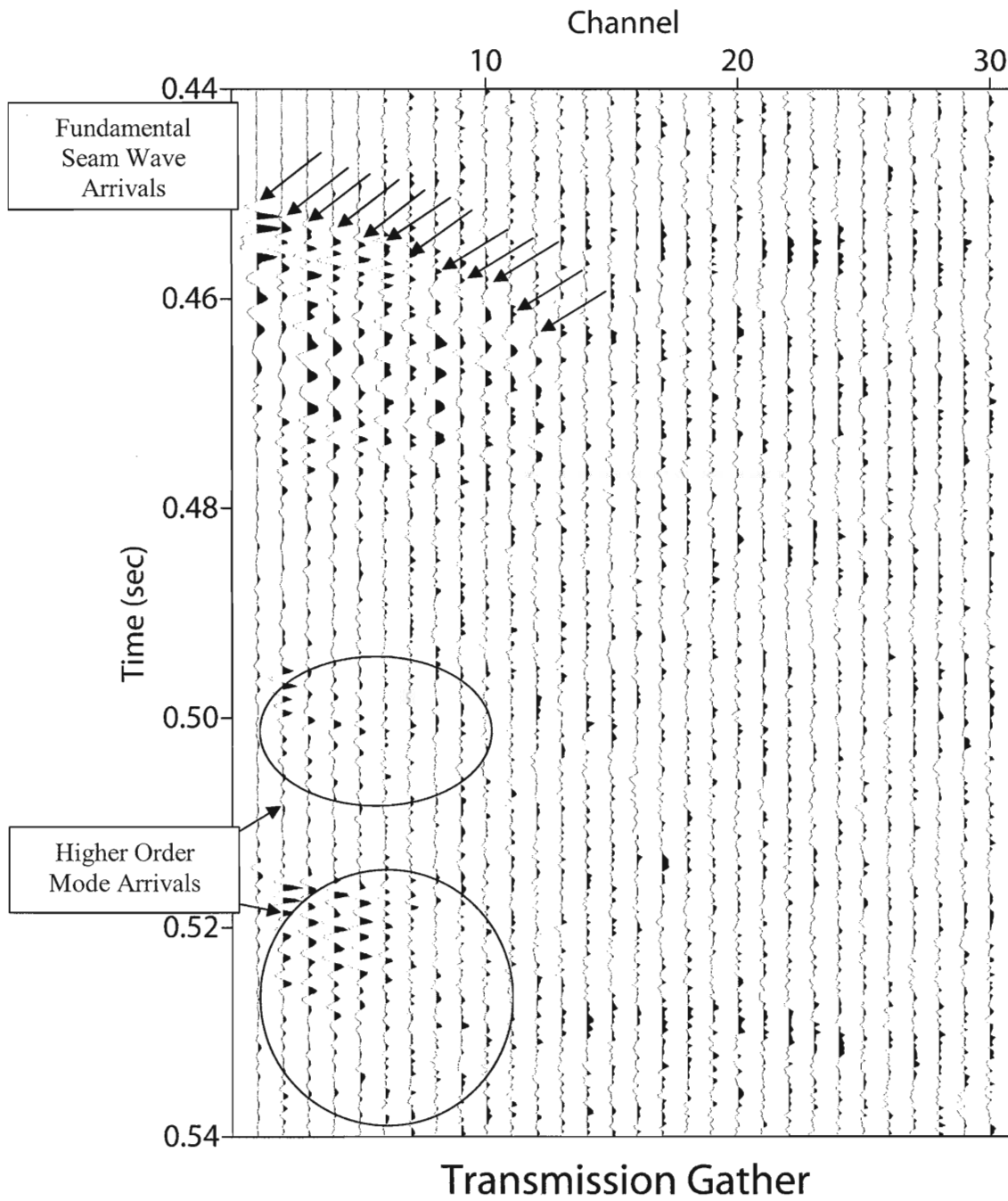

**FIGURE 6: TRANSMISSION GATHER**

A transmission gather indicating the presence of a seam wave. Note the lack of the seam wave from channels 15-30. This is due to the blockage of the seam wave.

## 5.0 DATA PROCESSING FOR ISS SURVEYS

### 5.1. Data and Interpretation

Data processing was performed by Virginia Tech under the guidance of Dr. Imhof at the campus facility in Blacksburg Virginia. As mentioned earlier, the primary difficulties encountered with in-seam surveys are channel wave velocities and their dispersion characteristics. The Researchers used the same processing sequence for both in-seam reflection surveys. The in-seam reflection data gathered by the geophones was first compressed in order to undo dispersion. After establishing the seismic velocity of the channel wave as a function of frequency, the Researchers determined the dispersion relationship. The dispersion relationship was used to undo the dispersion by compressing the extended wave train into a shorter one. In addition, the transmission data revealed the presence of seam disruptions between the mine and the seam outcrop. After loading a coordinate reference, and editing the traces, the Researchers applied a bandpass filter (10-100 and 750-1000 Hz) to remove low frequency ground roll and high frequency noise.

Two different dispersion analysis techniques were utilized to verify the correct identification of the dispersive channel waves. First, a moving window Fourier analysis was used, and in general was found to be inadequate for determining dispersion. The Multiple Filter Technique (MFT) developed by Dziewonski et al (1969), was used and found to determine the dispersion more quantitatively. The results from this analysis confirmed the dispersive nature of the previously identified wave events and thus that the reflections used for imaging purposes were indeed dispersed channel waves. See *Appendix A* for additional explanation.

A true amplitude correction was then applied to the bandpass filtered data to account for spherical divergence. The Researchers observed that the data were contaminated by 60 Hz powerline noise because coal mining equipment in nearby mines is operated on electric power. A predictive deconvolution (lag 16.6 ms) was applied to remove this periodic powerline noise. *Figure 7* is a shot gather after bandpass filtering and true amplitude recovery have been applied. The dispersive reflected channel wave arrival is clearly visible at approximately 0.8 seconds. The Researchers removed the strong airwaves (Air Blast attenuation) by automated surgical muting and where appropriate, applied manual mutes to remove direct body and surface waves. An automatic gain control was applied to balance the remaining data. Instead of dispersion compression (Mason et al. 1980), the Researchers transformed the amplitude traces to envelope traces as shown in *Figure 8*. *Figure 8* is the edited strip chart recording trace for all active geophones from a single explosive event. As identified in Section 3.6, there were 35 such traces available for ISS Line 1 and 37 traces available for ISS Line 2. The dispersive wavetrains with a duration of ~20 ms were thus transformed to 50 Hz wavelets exhibiting positive amplitudes only. This procedure is similar to amplitude demodulation used for radio transmissions.

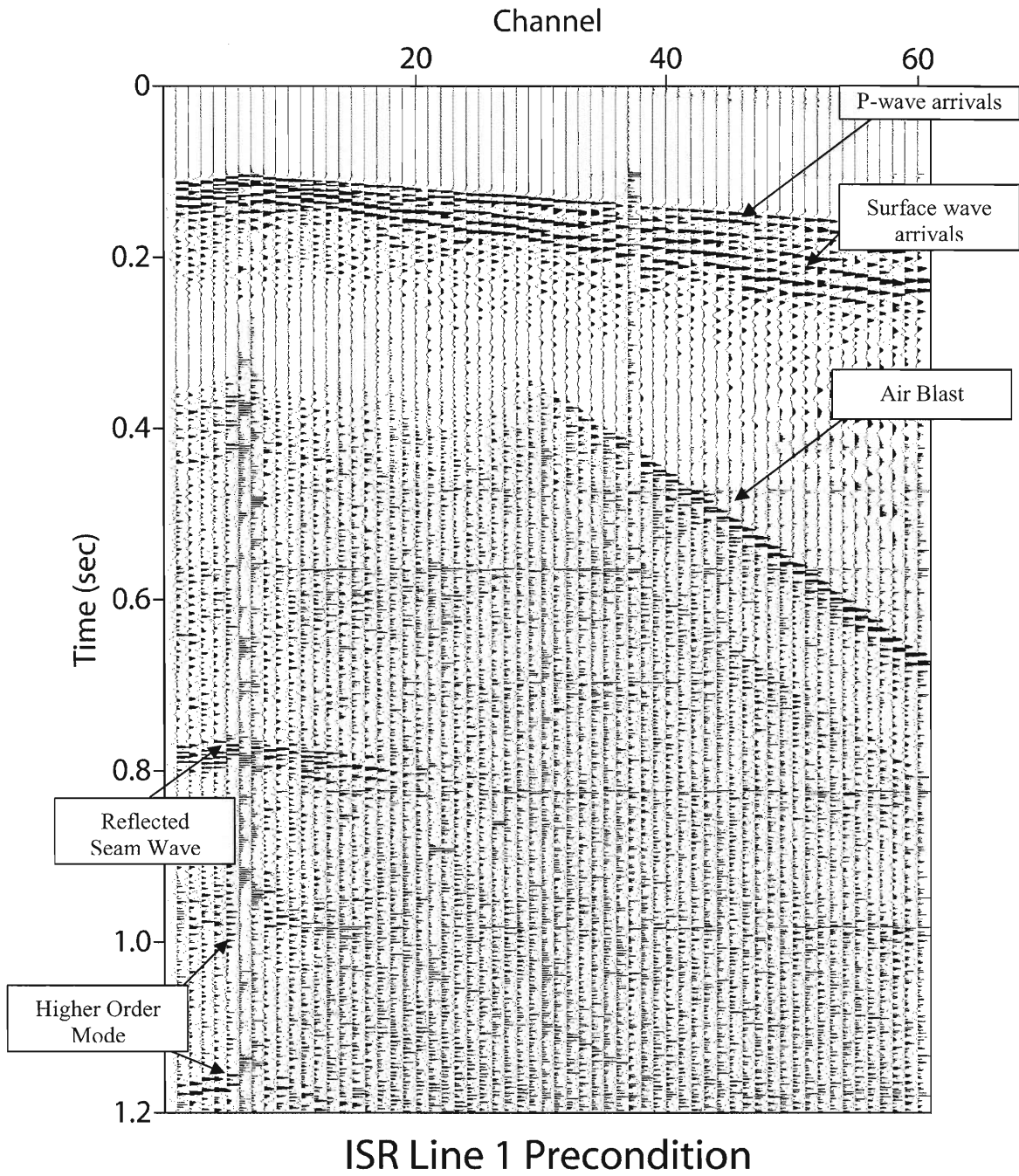

**FIGURE 7**

The transmission gather after bandpass filtering and Predictive deconvolution and amplitude correction clearly shows a reflection surface channel wave reflection at 0.8 seconds. However, the reflection surface is only detected by geophones 1-20 suggesting a void on that side.

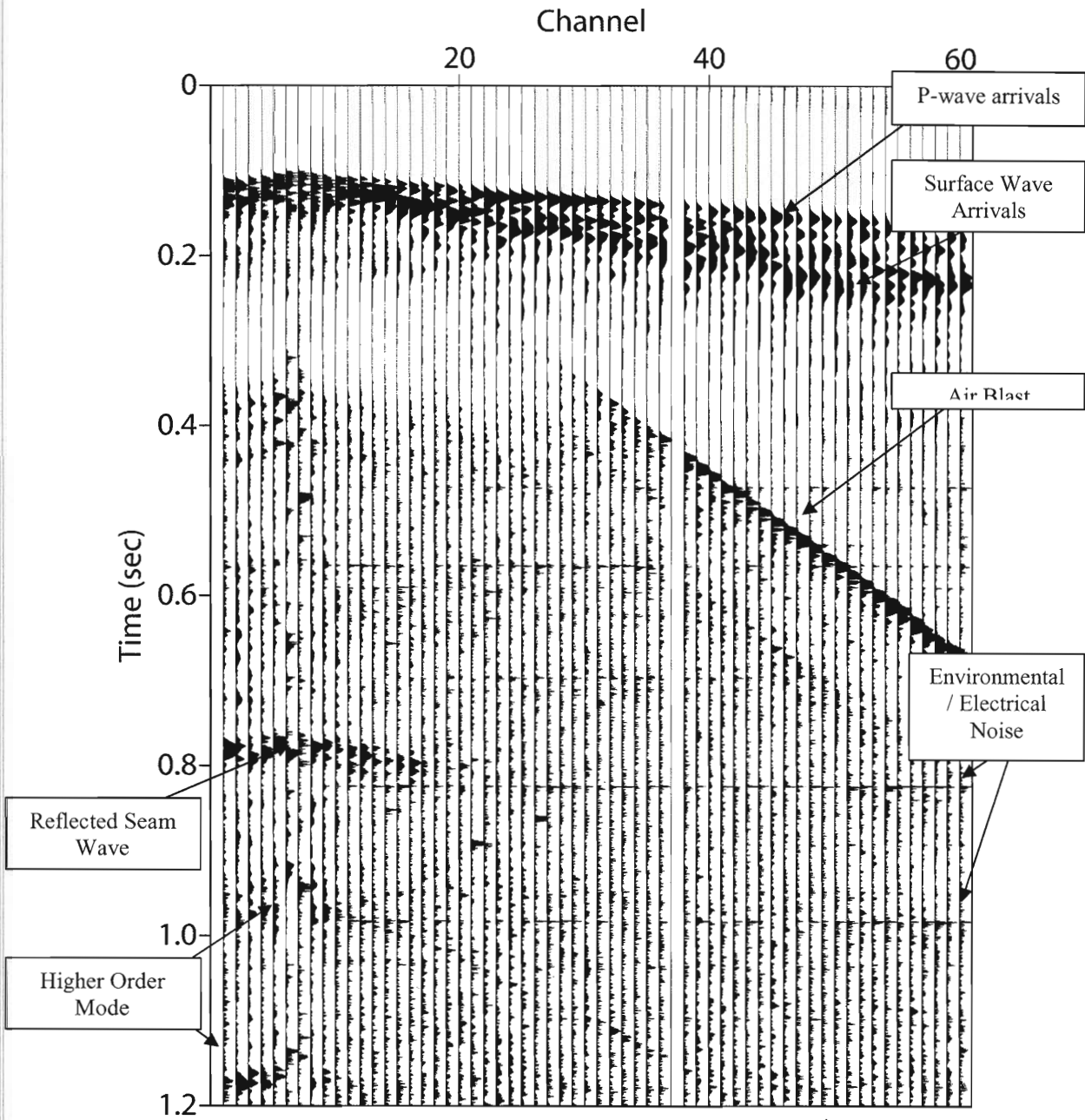

ISR Line 1 Envelope Formation

FIGURE 8

The previous Transmission gather after envelope formation more distinctly shows the reflected channel wave.



Instead of redeveloping earlier imaging methods (Buchanan et al., 1981), the Researchers used conventional PreStack Depth Migration (PSDM) for imaging. Migration is assumed to be in depth. Our surveys, however, require lateral imaging. To reduce imaging artifacts, the site geometry was rotated 90 degrees along a horizontal axis chosen to approximate the crooked geometry of the coal seam best. Lateral distance from the axis was thus converted to pseudo-depth, topography became pseudo-crookedness, and crookedness (the lateral distance of sources and receivers from the axis) became pseudo-topography. Because the seam is essentially flat along the surveys, pseudo-crookedness is small. The effects of pseudo-topography (true crookedness), however, can be corrected as part of the Kirchhoff depth migration. Using industry-standard seismic data processing packages such as **ProMAX**, the Researchers stacked the results of all shots (combined the traces shown in *Figure 8 - 35* for ISS Line 1 and 37 for ISS Line 2) to obtain the final images (See *Figure 9* and *Map 2* for ISS Line 1 and *Figure 10* and *Map 3* for ISS Line 2). The velocity model for the migration was a constant velocity of 460 m/s (1,510 ft/s) as determined from the transmission survey. To examine the effects of velocity model errors, the Researchers used models with constant velocities in the range between 445 m/s (1,460 ft/s) and 475 m/s (1,558 ft/s). These tests all showed the same mine reflectors with comparable sharpness, albeit with slightly different distances from the axis.

## 5.2. Results of ISS Line 1 Survey

The stacked reflection images for Line 1 are shown on Map 2. The strongest reflections are observed at a distance of approximately 380 m (1,246 ft). Due to relocating ISS Line 1, as described in Section 3.2, the actual mine voids are further east and further north of the seismic location. The migrated data image is approximately 30.5 m (100 ft) from the perpendicular projection, thereby indicating the presence outside the indicated image space. There are several possible reasons for this shadow effect. First, there are edge effects because the mine is located near the edge of the source and receiver arrays. Second, the mine voids in this area have multiple reflection diffraction point surfaces, identified as points A, B, and C on Map 2. Variations in the reflected channel waves are stacked during the data processing phase and merge multiple diffracting reflections into a single reflection event as shown in the image on Map 2. The inability to project a more definitive reflection boundary, other than in the area shown, suggests that the mine workings are to one side and that the distance is no closer than the location shown.

**FIGURE 9: STACKED IN-SEAM REFLECTION LINE 1**

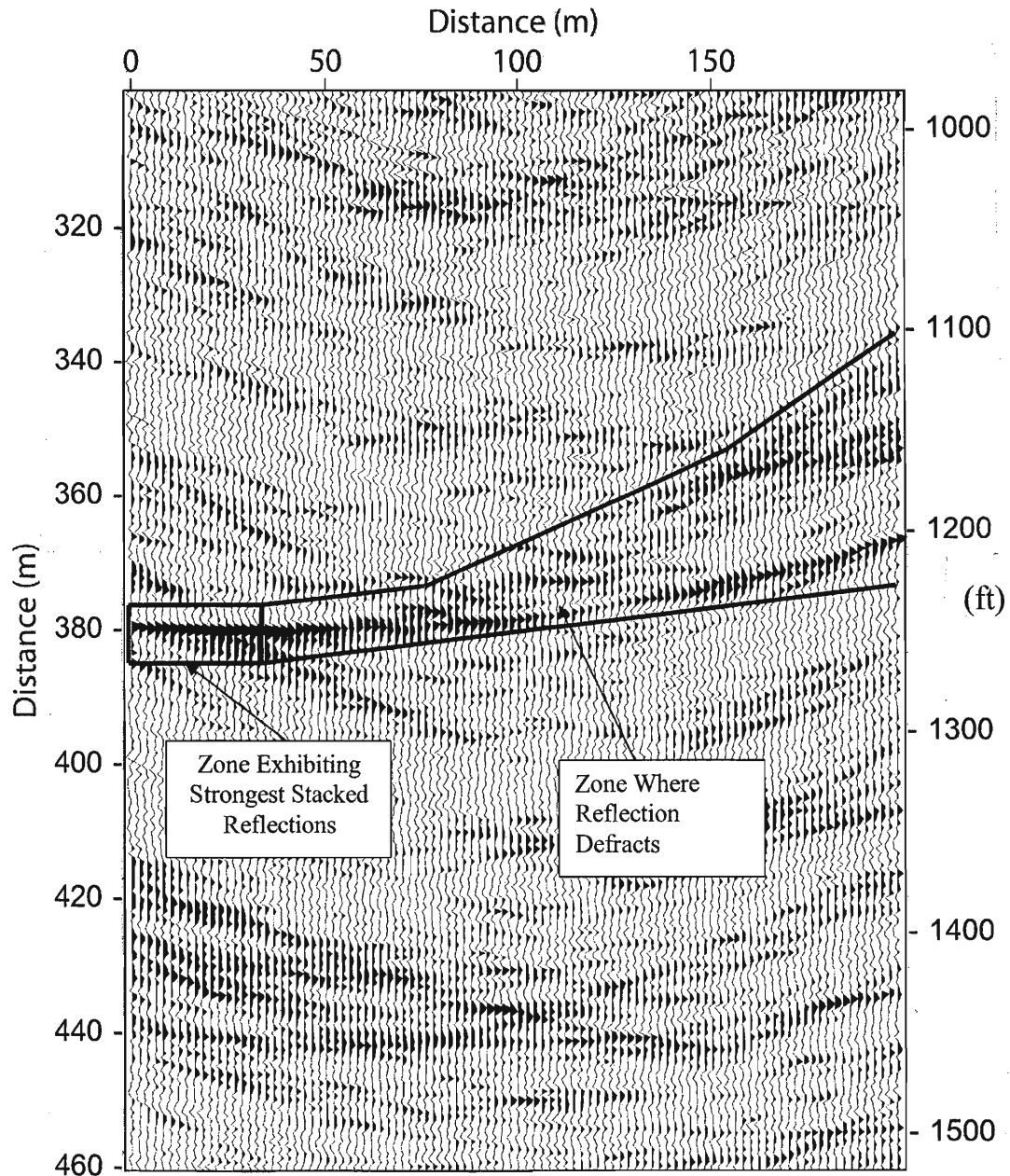

ISR Line 1 Stack

**FIGURE 10: STACKED IN-SEAM REFLECTION LINE 2  
(COMBINATION OF 37 INDIVIDUAL EDITED REFLECTION GATHERS)**

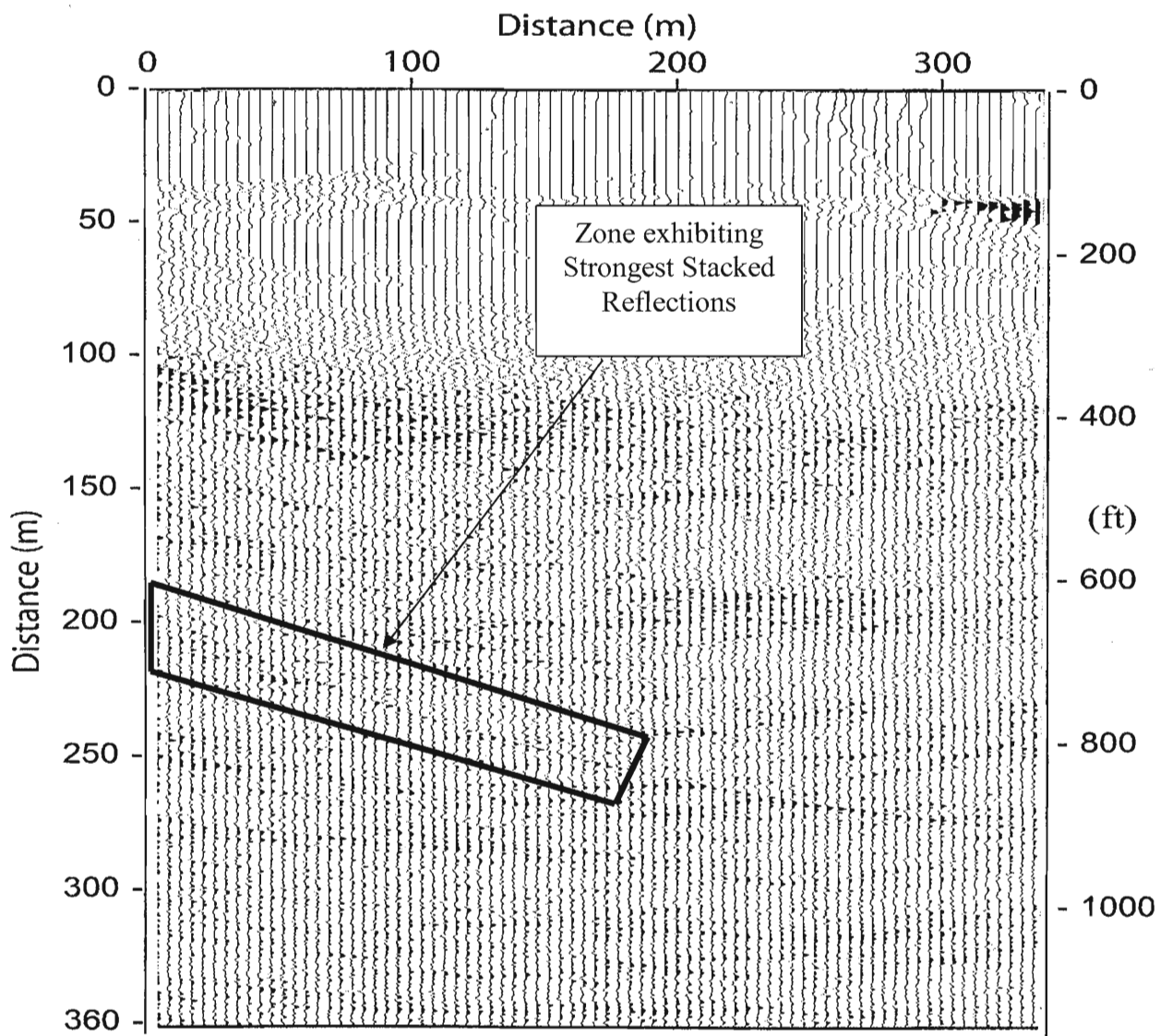

ISR Line 2 Stack

### 5.3. Results of ISS Line 2 Survey

The full reflection image for Line 2 is shown on *Map 3*. The distance to the void changes along the seismic profile because the seismic line and the mine boundary are at an oblique angle. The closest seismic source at Hole No. 2-1380B is 210 m (640 ft) from the mine works, while the seismic source at Hole No. 2-300B is 390 m (1,280 ft) distant (both based upon a perpendicular projection from the source receiver line). This angle causes much of the seismic energy at the greater distances to be reflected away from the geophones, while the seismic energy tends to concentrate where the mine works are closest together. Consequently, the right or eastern side of the seismic line has more reliable data while the left or west side has a lower level of certainty. The seismic projection of the mine works therefore changes as the actual mine moves away from the seismic line. The accuracy of the in-seam seismic results was checked against the existing mine survey. The following table summarizes the deviations between the actual mine void and the seismic survey against the horizontal distance along the crop starting from Hole No. 2-1290B and increasing westward.

**Deviation between Actual and Seismic Distances (Feet)  
 at a Seismic Velocity of 1,510 ft/s**

Distance along Crop	Actual Distance	Seismic Distance	Deviation	Percent Deviation
150	704	694	10	1.42%
200	840	825	15	1.79%
400	983	938	45	4.58%
580	1095	1000	95	8.68%
670	1150	1028	122	10.61%

This table is based on a seismic velocity of 460 m/s (1,510 ft/s) which is the fastest transmission time for the dispersed wave train. If the slowest response time for the wave train of 440 m/s (1,440 ft/s) is used, then the following deviations are estimated:

**Deviation between Actual and Seismic Distances (Feet)  
 at a Seismic Velocity of 1,440 ft/s**

Distance along Crop	Actual Distance	Seismic Distance	Deviation	Percent Deviation
150	704	728	-24	3.37%
200	840	865	-25	2.99%
400	983	984	-1	0.06%
580	1095	1049	46	-4.24%
670	1150	1078	72	-6.26%

By using the slower seismic velocity, the accuracy of the seismic survey increases. At a seismic velocity of 460 m/s (1,510 ft/s), which is the fastest transmission time, only 82m (268 ft) of the seismic line is within a deviation of plus or minus five percent ( $\pm 5\%$ ). If the slower seismic velocity of 440 m/s (1,440 ft/s) is used, then approximately 141 m (468 ft) of the seismic line is within a deviation of ( $\pm 5\%$ ).

## 6.0 OBSERVATIONS

The results presented indicate that in-seam seismic methods can be used for void detection, although the results require some interpretation. The Researchers anticipated detection of the mine voids located approximately 305 m (1,000 ft) from the seam outcrop with an accuracy of  $\pm 9.1$  m ( $\pm 30$  ft). The stated level of accuracy can be achieved given appropriate density of data collection, a proper selection of survey parameters, and an accurate measurement of the velocity of the channel wave. The demonstration also identified that the detection of voids is independent of the type of mine fill, as both air and water-filled voids were detected.

In the Line 1 survey, the Researchers were able to identify the presence of a void, although its specific location was approximate due to the inconsistent reflection of the irregularly shaped mine works across the seismic line. The location of the mine void to the right of the perpendicular projection of the seismic line indicates an ability to locate objects not in the direct line of view. In the Line 2 survey, the Researchers were able to locate the mine void moving away from the seismic line. The mine void was identified with a deviation of less than 5% of the known distance to the mine. However, variations in seismic velocity were shown to have a significant impact on the accuracy of the location. In this demonstration, a seismic velocity based upon the trailing edge of the dispersed channel wave improved the accuracy of the location by allowing more of the mine works to within 5 percent of the actual distance. Likewise, the density of the data coverage (the aperture of the reflection data) also has a significant impact on the survey location. The density of the data coverage is based upon the acquisition parameters of the in-seam survey. The denser seismic array as existed on the east side of Line 2 contributed to better detection and mapping of the mine voids.

Processing steps used for this demonstration project improved the ability to identify reflected channel waves from in-seam surveys. Based upon the workflow shown below, the techniques presented to interpret the seismic data suggest that the user need not be a researcher, but some specialization and training in appropriate programs is required.

Step	Description
A	Load Geometry
B	Trace Edit
C	Bandpass Filter ~ 10-100 and 750-1000 Hz
D	True Amplitude Recovery (time raised to a constant power)
E	Predictive Deconvolution (lag 16.6 ms)
F	Air Blast Attenuation
G	Mute (if necessary)
H	Automatic Gain Control (window length 150 ms)
I	Envelope Formation (Demodulation)
J	PreStack Depth Migration
K	Image Stacking

The processing during the demonstration indicated that the removal of powerline noise can be accomplished through predictive deconvolution, that the bandpass filter range should include all frequencies associated with the fundamental and higher order modes, and that the removal of high amplitude air blast can be accomplished through automated and surgical muting. In addition, the effects of spherical divergence associated with geometric spreading of the wave front can be corrected using true amplitude recovery, and that the wavelet compression used by others (Buchanan et al. 1981, Mason et al. 1980) can be replaced with envelope formation. Finally, PSDM is available in standard seismic data processing software from both commercial and public domains. Processing is easier if the survey line is fairly linear rather than being a rough line with significant pseudo-topography corrections.

## **6.1. Advantages and Limitations of In-Seam Seismic Technology**

The use of in-seam seismic technology has both strengths and weaknesses. The demonstration project identified technology that can be more effective in certain conditions than other methods. When possible, a transmission test to verify the channel wave velocity for a given condition will improve the accuracy for the depth migration of the image, rather than using an assumed velocity.

### **6.1.1. Detection includes All Subsurface Anomalies**

Current seismic technology indicates that any abrupt change in the seam, however small, will reflect channel waves. Hence, faults or changes in seam thickness also cause reflections, which may be difficult or impossible to distinguish from voids, and may require resolution by drilling. More extensive use of in-seam seismic reflection data may enable refinement of the technique to distinguish such differences. Both Buchanan et al.<sup>12</sup> and Hanson et al.<sup>13</sup> showed that a fault or void may effectively block the passage of channel waves, and thus, can prevent detection of more distant voids and other features.

Detection of faults and seam discontinuity, however, is of great value to mine planning

### **6.1.2. Probable Disruption of Normal Mining Activities**

Underground mining activities are disturbed if the seismic survey is performed in an actively mined area. Ideally, nearby mining activity and the use of heavy machinery would have to be stopped during the seismic survey to minimize the contamination of seismic data by cultural noise. Potentially, mining activity could serve as the seismic source, in effect using the mining-induced seismic noise as the source. This seismic source option would lessen the disruption of mining activity because only seismic receivers, and not sources, need to be deployed and protected.

---

<sup>12</sup> D. J. Buchanan, R. Davis, P. J. Jackson, and P. M. Taylor. Fault Location by Channel Wave Seismology in United Kingdom Coal Seams. *Geophysics*, 46(07):994-1002, 1981.

<sup>13</sup> D. R. Hanson, T. L. Vandergrist, M. J. DeMarco, and K. Hanna. Advanced Techniques in Site Characterization and Mining Hazard Detection for the Underground Coal Industry. *Int. J. Coal Geol.*, 50:275-301, 2002.

### **6.1.3. Special Site Preparation is Required**

Ideally, generic geophones are sited directly on the seam face, which requires a smooth face and an un-fractured and un-weathered seam to reduce generation of near-source or near-receiver noise. Such a face may need to be prepared. Specifically, as an alternative, borehole receivers can be placed in short holes (3-10 ft) which are drilled for this purpose. Additional boreholes may be needed depending on the type of seismic source used for the survey, for example, explosives.

### **6.1.4. Detection is Independent of Void Material**

Research has demonstrated that air-filled voids reflect channel waves more effectively than water-filled or debris-filled ones. The underground presence of water, gases, slurry, or gob does not affect the reflection of the channel wave, only the amplitude of the reflection. In some instances a widespread, patchy mixture of water and gas, magnifies such attenuation. In addition, a channel wave is not affected by voids in upper or lower seams, unless the seams are spaced so closely that their channel waves couple and in effect propagate as one single channel wave.

### **6.1.5. Other Considerations**

The application of in-seam seismic technology does not cause any environmental problems beyond the mining activity. Seismic equipment is designed for use in harsh environments and should not need additional protection or modifications.

### **6.1.6. Processing to Allow Widespread Application**

Acquisition, processing, and interpretation of in-seam seismic data currently require expert knowledge. Most likely, in-seam seismic void detection will initially be provided by an independent contractor; however, over time, acquisition should become routine and public domain processing software should allow large degrees of automation. Currently, software for routine processing of in-seam seismic data may be incomplete and may need to be developed. No stand-alone software package exists that performs processing and interpretation with minimal operator input.

## **7.0 CONCLUSIONS**

The ISS method is limited for detecting voids and discontinuities associated with coal seams. Variations in seismic velocity in a coal seam can result in inaccurate distance determinations to a mine. The workflow presented here can be successfully applied to an ISS survey and used for detection and imaging purposes, replacing customized data processing utilities with packaged, commercially and publicly available software. Current drilling programs can be replaced with targeted drilling that utilizes data from in-seam surveys.

## **8.0 RECOMMENDATIONS**

This seismic survey demonstration was applied at a seam outcrop, although the application can potentially be extended for use in an underground mine before new mining operations commence in an old area or during mine operation downtime. Additional research and development are required to perfect the current systems for use underground in intrinsically safe enclosures and connections. This technology can also be potentially extended to borehole generation of channel waves for void detection. Additional projects would be required to demonstrate the application of locating a mine void from a series of boreholes.

Void detection utilizing ISS methods is feasible, although the exact location of the void interface can be more difficult to map due to data coverage, diffractors along the void interface and other variables associated with the coal seam and mine environment. This demonstration suggests that by utilizing in-seam seismic methods for targeting potential voids, “exploratory” drilling can be used more precisely to intercept mine voids.

During this demonstration, explosive charges were used as a source of seismic waves. Different types of sources can also be used and their use should be evaluated. For distances up to 200 m (650 ft) a hammer source is adequate for generating detectable channel waves. For distances up to 500 m (1,640 ft) charges of 0.11 kg (1/4 lb) are sufficient for generating channel waves used for detection and imaging. Other sources, such as a shotgun or piezoelectric devices, may also be sufficient for generating channel waves.

Better seismic data coverage will generally provide better detection and imaging using in-seam seismic techniques. Linear seismic arrays are easier to evaluate than crooked seismic arrays, although both geometrics can be used. A long seismic array will typically be better than a short array, lending better data coverage and aperture. Additional study is warranted in developing methods to readily convert crooked seismic waves to more easily interpret seismic data.

## **9.0 ACKNOWLEDGEMENTS**

The authors wish to acknowledge the generous support and help of TECO, the Virginia DMME, Virginia Tech and various contractors whose assistance was needed for the completion of this project.





**Photograph 1** Equipment Used for Site Preparation



**Photograph 2** Original Condition of Site



**Photograph 3** Access Road Prepared First



**Photograph 4** Site Ready for Coal Seam Exposure



**Photograph 5** Exposing the Coal Seam



**Photograph 6** Partially Exposed Coal Seam



**Photograph 7** Maintaining the Site after a Bank Slip



**Photograph 8** Exposing the Coal Seam



**Photograph 9** Exposing the Coal Seam



**Photograph 10** Exposed Coal Seam



**Photograph 11** Exposing the Coal Seam



**Photograph 12** Exposed Coal Seam



**Photograph 13** Site Access



**Photograph 14** Preparing the Site



**Photograph 15** Preparing the Site



**Photograph 16** Preparing the Site





**Photograph 17** Drilling Blast Holes



**Photograph 18** Placing Charge



**Photograph 19** Blast Hole (Source) Wired and Ready



**Photograph 20** Source Hole After Blast



**Photograph 21** Placing Geophone



**Photograph 22** Locations for Geophones and Source Holes



**Photograph 23** Seismic Equipment

---

## GLOSSARY

---

Adaptive Lag Sums (ALS): Processing technique similar to Kirchhoff prestack depth migration. A horizontal map of the part of the coal seam under investigation is defined and divided into cells. Knowing the cell location, shot location and geophone location, the group velocity at a particular frequency is chosen, and the travel time of the corresponding wave group from the shot to a reflecting cell and then to the geophone is calculated. The amplitude of the recorded trace contributes to the image and contributions from all common shot traces are summed to produce a final image.

Aperture: A portion of a data set to which functions or filters are applied.

Automated Surgical Muting: See Muting.

Automatic Gain Control (AGC): A system to control the increase in the amplitude of an electrical signal from the original input to the amplified output. Commonly used to improve visibility of weak or late-arriving events and to balance data amplitudes.

Bandpass Filter: A filter that passes a range of frequencies unaltered while rejecting frequencies outside the range defined by the user.

Channel Wave: See seam wave.

Common Depth Point (CDP): In multi-channel seismic acquisition in flat layered strata, the halfway point between source and receiver.

Critical Angle: The angle of incidence according to Snell's law at which a refracted wave travels along the interface between two media. Characterized mathematically as:

$$\sin(\theta_c) = V_1/V_2,$$

where  $\theta_c$  = critical angle,  $V_1$  = velocity of first medium,  $V_2$  = velocity of the second medium, which is higher than  $V_1$ .

Deconvolution: A process used to reverse the effects of convolution on recorded data. The seismic signal to be recovered has been convolved with some other noise that can be mathematically removed from the signal.

Demodulate: A term used to describe the extracting of a periodic amplitude(s) in a wavetrain such that the desired signal is isolated.

DiffraCTOR: A discontinuity that produces radial scattering of a wave into new wavefronts.

Dispersion: Type of distortion of a wavetrain in which each frequency component is propagating with a different velocity. The use of compression to “undo dispersion” refers to reducing the amplitude of a portion of the wave train to isolate the average frequency within the wavetrain.

Dynamic Trace Gathering (DTG): A generalization of NMO. A hypothetical reflector is systematically tested through a range of orientations in which at each midpoint, traces with source-receiver combinations which satisfy angle-of-incidence equals angle-of-reflection are selected, moveout corrected, and stacked.

Envelope Traces: See page 14 in the text.

Fresnel Zone: A frequency and range dependent area of a reflector from which most of the energy of a reflection is returned. Arrival times differ by less than half of the dominant period of the reflection wavelet.

Fourier Analysis: The mathematical decomposition of any wave in terms of a sum of a group of sinusoidal waves (normal modes) of properly chosen amplitudes that can be recombined to obtain the original wave.

Fundamental Mode: Lowest frequency oscillation of a standing wave consisting of a vibration with a single maximum that is characteristic of the medium in which the wave is propagating. (See Mode, Normal Mode).

Gather: The recorded trace of the response of a geophone to a seismic wave.

Geophone: A highly sensitive ground motion transducer, which uses the motion of a spring supported coil suspended in the field of a permanent magnet to generate an output signal.

Group Velocity: The speed at which wave packets in a seismic wave move.

Guided Wave: See seam wave.

Higher Order Mode: A normal mode of a wave with a higher frequency.

Hilbert transform: Signal that has been phase shifted by 90 degrees.

Impedance: Product of density and seismic velocity. Typically denoted as  $Z = \rho * V$  where Z is the impedance, V is the velocity of the medium and  $\rho$  is the density of the medium.

In-Seam Reflection Survey (ISR): Seismic survey in which In-Seam methods are used to acquire reflected channel waves for imaging purposes.

In-Seam Seismic (ISS): A type of seismic method in which sources and geophones are located within a coal seam.

In-Seam Transmission Survey (IST): Seismic survey located within a seam with a known distance between source and receiver. Typically used to determine local seam wave velocity of the coal.

Kirchhoff Prestack Depth Migration: Method of seismic migration that uses the integral form (Kirchhoff equation) of the wave equation. The Kirchhoff integral defines a field at a given point as a weighted superposition of waves propagating from adjacent points and times. Requires a background velocity model.

Layerstack: Seismic model representing different layers of a medium with different velocities. An example is a Sandstone/Shale/Coal/Dirt Band/Coal/Shale/Sandstone sequence with each layer (separated by /) having its own material properties.

Leaky Mode: Multiply reflected seam wave that radiates into the surrounding country rock.

Love Seam Wave (also known as Evison wave): Type of seam wave whose particle motion is horizontally transverse to the direction of propagation (SH-type motion).

Migration: Correction that is applied in reflection shooting in the case of dipping boundary planes by which the reflection points, that are originally plotted vertically downwards, are shifted to their proper position.

Mode: any of various stationary vibration patterns of a wave in an elastic body, or in an oscillatory system.

Moving Window Fourier Analysis: A technique of wave analysis where the normal modes of a wavetrain are isolated over a certain distance along the length of the wavetrain. See Fourier Analysis

Multiple Filter Technique (MFT): Technique for analyzing dispersed signals. The spectrum of the trace is decomposed into several frequency ranges using narrow bandpass filters with different center frequencies. The frequency plotted against time can then be obtained and hence provide dispersion characteristics for the signal.

Muting: Removing the contribution of selected seismic traces in a stack to minimize air-waves, ground roll, or other unwanted noise. Muting that is applied specifically for known interference such as air blast vibration and which can be removed automatically in the processing program. is referred to as “automated surgical muting”.

NMO (Normal Moveout Correction): A function of time and offset that can be used in seismic processing to compensate for the effects of the delay in reflection arrival times when geophones and shotpoints are offset from each other.

Normal Modes: Oscillations in a wave that are harmonic in both frequency and amplitude, and are characteristic of the propagating medium.

Offset: A number indicating the distance (displacement) from the start of a data structure object and up to a given element.

P-Wave: A sound wave in which particles oscillate in the direction the wave propagates.

Phase Velocity: The speed at which any fixed phase of a wavelet (such as a peak or a trough) travels.

Predictive Deconvolution: A type of inverse filtering in which the effects of the filter are known by observation or assumed. For our case, inverse filtering is used to attenuate 60-HZ power line noise.

Pseudo-Rayleigh Wave (also known as Krey wave): Type of seam wave whose particle motion is vertical and longitudinal to the direction of wave propagation (combination of P and SV waves).

S-Wave: An elastic body wave in which particles oscillate perpendicular to the direction in which the wave propagates. There are two types of S-Waves: SV (vertically polarized) and SH (horizontally polarized).

Seam Wave: A type of wave propagating in a confined layer whose velocity is less than that of the boundary layers (i.e. above and below the propagating strata).

Signal to Noise Ratio (S/N): A measure of seismic signal strength relative to background noise.

Stacking: Technique of averaging seismic trace gathers to improve the signal to noise ratio of data.

Surface Reflection Seismic Survey: An exploration technique where a series of geophones are placed along a line on the surface of the earth, and respond to seismic waves that are generated by a wave source on the surface and that are reflected by subsurface anomalies.

Trace Envelope: Commonly formed to aid in stacking procedures. Formed from the analytical signal or complex trace found through the Hilbert transform of the seismogram.

True Amplitude Correction: An amplitude correction factor to account for spherical divergence (geometric spreading) of the wave front.

Undo Dispersion: See Dispersion.

Waveguide: A layer of material that acts as a medium for transmitting guided waves (i.e. coal).



---

## REFERENCES

---

- Aki, K., and Richards, P., 2002, Quantitative Seismology: University Science Books
- Buchanan, D.J., Davis, R., Jackson, P.J., and Taylor, P.M., Fault location by channel wave seismology in United Kingdom coal seams. *Geophysics*, 46: 994-1002. 1981.
- Dombrowski, B.A., Dresen, L., and Rüter, H. Physics of Channel Waves in Coal Seams. Handbook of Geophysical Exploration. Seismic Coal Exploration Part B: In-Seam Seismics. 16 B:1-93, 1994.
- Dziewonski, A.M., Bloch, S. and Landisman, M. "A technique for the analysis of transient seismic signals", *Bulleting of the Seismological Society of America*. 59, 427-444. 1969.
- Evison, F.F. A Coal Seam as a Guide for Seismic Energy. *Nature*, 176:1224-1225, 1955.
- Hanson, D. R., Vandergrist, T. L., DeMarco, M. J., and Hanna, K. Advanced Techniques in Site Characterization and Mining Hazard Detection for the Underground Coal Industry. *Int. J. Coal Geol.*, 50:275-301, 2002.
- Herrmann, R., 2004, Computer Programs in Seismology-An Overview of Synthetic Seismogram Computation, Version 3.30: St. Louis University <http://www.eas.slu.edu/People/RBHerrmann/CPS330>.
- Imhof, M.G. "Calculating the Seismic Effect of 3D Underground Structures and Topography with the Finite-Difference Method," 72<sup>nd</sup> Annual International Meeting of the Society of Exploration Geophysicists, Salt Lake City, 2002.
- Imhof, M.G., Diplom, "A Seismostratigraphic Contribution to the Classification of Gravel Deposits in the Rafzerfeld," Eidgenoessische Technische Hochschule, Switzerland, 1991.
- Imhof, M.G., Toksoez, M. N. , Burch, C. I., and Queen, J. H., "Near Surface Scattering from High Velocity Carbonates in West Texas," *Journal of Seismic Exploration*, 8(4), 221-242, 1999.
- Imhof, M.G. and Toksoez, M. N. "Calculating Seismic Source Signatures for Explosions in and around Cavities," *Bulletin of the Seismological Society of America*, 90(1), 229-242, 2000.
- Imhof, M.G. "Scale Dependence of Reflection and Transmission Coefficients," M.G. Imhof, *Geophysics*, 68(1), 322-336, 2003.
- Imhof, M.G. "Computing the Elastic Scattering from Inclusions Using the Multiple Multipoles Method in 3D," M.G. Imhof, *Geophysical Journal International*, in press.

- Krey, T.C. Channel Waves as a Tool of Applied Geophysics in Coal Mining. *Geophysics*, 28:701-714, 1962.
- Mason, I.M., Buchanan, D.J., Boorer, A.K., Channel Wave Mapping of Coal Seams in the United Kingdom *Geophysics*, 54(07): 1131-1143, 1980.
- Mullenex, C.P.G. C.G.W.P., R.H., Wiram, C.P.G., V.P., Naumann, P.E., H.E. “Integration of Hydrogeologic and Geophysical Techniques for Identification of AMD Seepage and Remedial Design,” April 1995
- Naumann, P.E., H.E. “Locating Abandoned Underground Coal Mines,” CAS-SME/WVCMCI, White Sulphur Springs, West Virginia, October 2001
- Naumann, P.E., H.E. R. Rodriguez, Ph.D., R. “Seismic Method as a Low Cost Alternative for Detecting Non-Coal Inclusions in Longwall Panels,” April 1994
- Naumann, P.E., H.E. R. Rodriguez, Ph.D., R. “Underground High Resolution Seismic Method as a Low Cost Alternative for Mapping Sandstone Replacement Channels in Coal Mines,” 13<sup>th</sup> Conference on Ground Control in Mining, Longwall USA, June 1994
- Nyman, D., and Landisman, M., 1977, The Display-Equalized Filter for Frequency-Time Analysis: *Bulletin of the Seismological Society of America*, 67, 393–404.
- Regueiro, J. S. Seam Waves: What are They? Part 1. The Leading Edge, 09(04):19-23, 1990.
- Snoke, J., and James, D., 1997, Lithospheric Structure of the Chaco and Paraña Basins of South America from Surface-Wave Inversion: *Journal of Geophysical Research*, 102, 2939–2951.
- Robinson, E.A., “Acquisition/processing – further to Norman Neidell’s series . . . Holistic Migration.”, *The Leading Edge*, 17(03): 313-320, 1998.

---

## APPENDIX A

### DETERMINING AND MODELING COAL SEAM WAVE CHARACTERISTICS

---

Numerical modeling of the transmission survey geometry was performed for comparison between synthetic data and the recorded field data. Lacking in-situ measurements, values for  $V_p$ ,  $V_s$ , and density were estimated from published data<sup>1</sup>. All computations were performed using the Computer Programs in Seismology (CPS) modeling package<sup>2</sup>. First, analytical solutions for the phase and group velocities of the Love and pseudo-Rayleigh type seam waves were computed using an analytical root finder (Herrmann's sdisp96 program). Second, synthetic seismograms were computed by numerical wave number integration where the hammer source was modeled by a horizontal force (Herrmann's hspec96 program). Three, simple 1-D layerstack models were created to approximate the conditions at the demonstration site.

This analysis required building a layerstack of the coal seam sequence, source and receiver descriptors, as well as source-receiver distances. The workflow can be generalized as follows:

- 1) Each model has a different stacking pattern (*Figure A 1*: rock\_1/coal/rock\_1 (symmetric), *Figure A 2*, rock\_1/coal/rock\_2 (asymmetric), and *Figure A 3* rock\_1/coal/dirtband/coal/rock\_1 (embedded dirt band).
- 2) A layerstack model consisting of P- and S- wave velocities, densities and thicknesses is defined by the user for all layers.
- 3) A numerical root finder solves the dispersion equation to determine group and phase velocities.
- 4) The Green's functions for the layerstack model are calculated for the desired source and receiver locations.
- 5) The source spectrum and the Green's function are multiplied in the frequency domain and converted into the time domain by the Fourier transform.

For the wave number integration, the synthetic trace that most accurately described our transmission survey setup was the transverse component for a horizontal point force (THF). *Figure A.4* shows all synthetic THF traces for the three types of coal seam sequences. A very well developed dispersed wavetrain starts to arrive at about 0.15 seconds for the symmetric and embedded dirt band sequences. The dispersed wavetrain arrives later for the asymmetric case. In addition, near 0.35 seconds, an arrival with a large amplitude is seen for all three cases which is interpreted as the Airy phase<sup>3</sup>. Airy phases are associated with extrema, typically minima, of the group velocity. Dispersion analysis of these events supports this interpretation.

---

<sup>1</sup> Dombrowski, B., Dresen, L., and Ruter, H., 1994, Seismic Coal Exploration Part B: In-seam Seismics: Elsevier Science Inc. Tarrytown, NY.

<sup>2</sup> Herrmann, R., 2004, Computer Programs in Seismology-An Overview of Synthetic Seismogram Computation, Version 3.30: St. Louis University <http://www.eas.slu.edu/People/RBHerrmann/CPS330>

<sup>3</sup> Aki, K., and Richards, P., 2002, Quantitative Seismology: University Science Books

Figures 4.5, 4.6 and 4.7 show the results of the Multiple Filter Technique (MFT) applied to the synthetic seam waves in Figure A.4. The program “mfilt”<sup>4</sup> was used for this analysis. This program is based on earlier work by Dziewonski and others<sup>5</sup>, However the mflit program incorporates enhancements including instantaneous frequency and the display enhancing filtering<sup>6</sup>.

Contours on each of the dispersion plots indicate the highest 20% amplitude values. As described above, the long periodic portion of the dispersed wave is seen earlier in the seismic trace, and hence has a faster group velocity. For all seam sequences, the large amplitude Airy phase is seen arriving last with frequencies of 700--1000 Hz and with a group velocity range of 500--600 m/s.

Analytical solutions for the Love and pseudo-Rayleigh coal seam waves were also computed using a numerical root solver to solve the dispersion equation for phase and group velocities<sup>7</sup>. The same layerstack models were used as for the wave number integration. Figure A 8 and Figure A 9 show the phase velocities for the first three modes for the Love and pseudo-Rayleigh seam waves. Dombrowski et al. showed that the phase velocities for the coal seam waves are bound between the shear velocities of the coal and surrounding rock. Figure A 8 and Figure A 9 confirm these bounds. Both the Love and pseudo-Rayleigh seam waves have phase velocities for all three modes that are bound between the shear velocities of the surrounding rock and coal.

Seismic events, however, propagate with the group velocity, not the phase velocity. Figure A 10 and Figure A 11 show the group velocities for the Love and pseudo-Rayleigh seam waves. The Airy phase arrivals (denoted by A) for the Love type seam wave drop below the shear wave velocity of the coal. Similar results are obtained for the pseudo-Rayleigh seam wave. There are many present for the pseudo-Rayleigh seam wave that is above or below the shear wave velocity of the coal.

Figure A 12 showed four traces extracted from the transmission survey at a distance of 220 m. Very nicely developed arrivals are seen at 0.46 seconds (fundamental mode arrival), and at 0.50, 0.52 and 0.58 seconds (higher order mode arrivals).

Dispersion analysis of the traces was carried out for comparison with the synthetic results. Figure A 13 shows the dispersion analysis for one selected trace. Contours indicate the highest 20% of amplitude values. The initial longer periodic portion of the seam wave is observed, followed by a large amplitude arrival. The frequency range for the interpreted Airy phase is between 700-1100 Hz with a group velocity range of 400-550 m/s. These results agree reasonably well with analytic solutions and wave number integration techniques for Airy phase arrivals.

---

<sup>4</sup>Snoke, J., and James, D., 1997, Lithospheric Structure of the Chaco and Paraña Basins of South America from Surface-Wave Inversion: *Journal of Geophysical Research*, 102, 2939–2951

<sup>5</sup> Dziewonski, A., Bloch, S., and Landisman, M., 1969, A Technique for the Analysis of Transient Seismic Signals: *Bulletin of the Seismological Society of America*, 59, 427–444.

<sup>6</sup> Nyman, D., and Landisman, M., 1977, The Display-Equalized Filter for Frequency-Time Analysis: *Bulletin of the Seismological Society of America*, 67, 393–404.

<sup>7</sup> Herrmann, R., 2004, Computer Programs in Seismology-An Overview of Synthetic Seismogram Computation, Version 3.30: St. Louis University <http://www.eas.slu.edu/People/RBHerrmann/CPS330>

With the geometry of geophones mounted perpendicular to the face of the coal seam, the Love seam wave is expected to be recorded more so than the pseudo-Rayleigh seam wave because the seam outcrop where the geophones were placed is subparallel to the line of sight from the source locations. If the geophones were mounted at an angle, one would obtain recordings for both the Love and pseudo-Rayleigh seam waves. Interestingly, the fundamental mode arrival seen for all traces in *Figure 3.4* shows a very short duration, higher frequency arrival, followed immediately by a lower frequency arrival over a time interval of approximately 0.02 seconds. The group velocity analytical solution for the Love seam wave shows three Airy phases with comparable group velocities and frequencies that reasonably correspond to the observed data. Also present in the field data are higher modes with increasing frequency content for each Airy phase arrival and a slower group velocity. These observations are consistent with the analytical solutions for either the Love or pseudo-Rayleigh seam wave group velocities. The fundamental mode arrivals and subsequent higher order mode arrivals for both the Love and pseudo-Rayleigh seam waves have very comparable group velocities. Hence, it is quite possible to have both the Love and pseudo-Rayleigh seam wave arrivals in the same data, although enhancement of the Love type seam wave is expected. ISS Line 1 should contain predominantly the pseudo-Rayleigh seam wave reflections, while ISS Line 2 should have reflections from both types of seam waves due to the angle between the coal seam outcrop and the mine-void interface. Since both the Love and pseudo-Rayleigh seam waves have comparable group velocities, we may have migrated a combination of both types.

The Airy phase for the fundamental mode of the coal seam wave is observed in both synthetic modeling and recorded data. The synthetic coal seam waves computed by wave number integration show well developed dispersion for the entire length of the trace with the Airy phase in a frequency range of 700-1000 Hz and a group velocity of 500-600 m/s. The analytical solutions for the Love and pseudo-Rayleigh seam waves indicate existence of multiple Airy phases, and modes, with a comparable group velocity and frequency range for the fundamental mode as seen in the recorded data. Compared to the wave number integration results, the field data do not show an equally well dispersed wavetrain for the coal seam wave, although the large amplitude Airy phase is observed with a similar range of frequencies (700-1100 Hz) and with a comparable group velocity (400-550 m/s) for both types of seam waves.

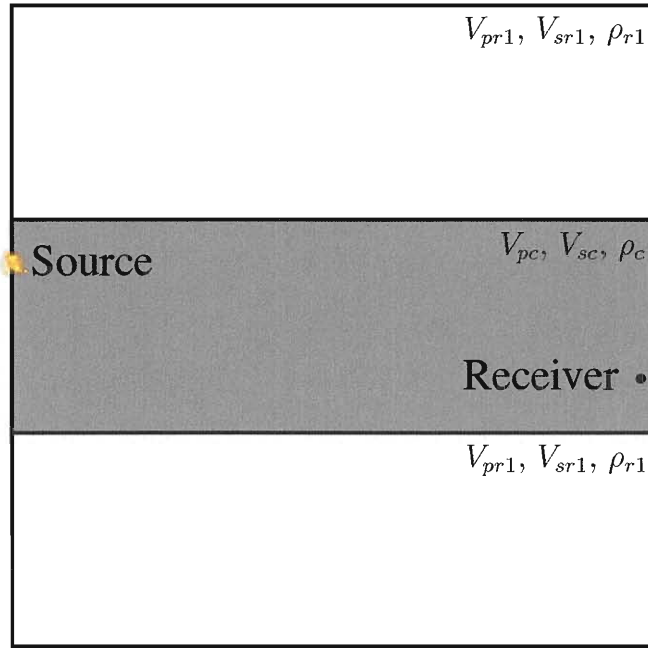

Figure A.1: Layerstack model for symmetric coal seam sequence.

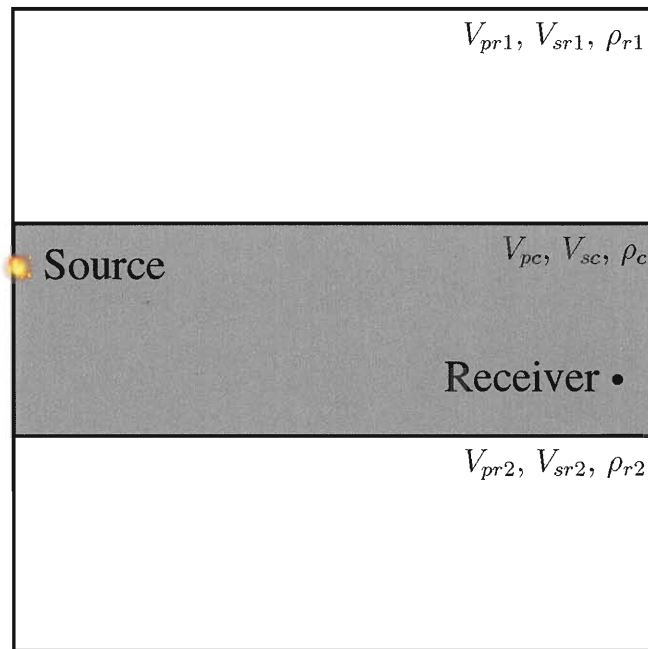

Figure A.2: Layerstack model for asymmetric coal seam sequence.

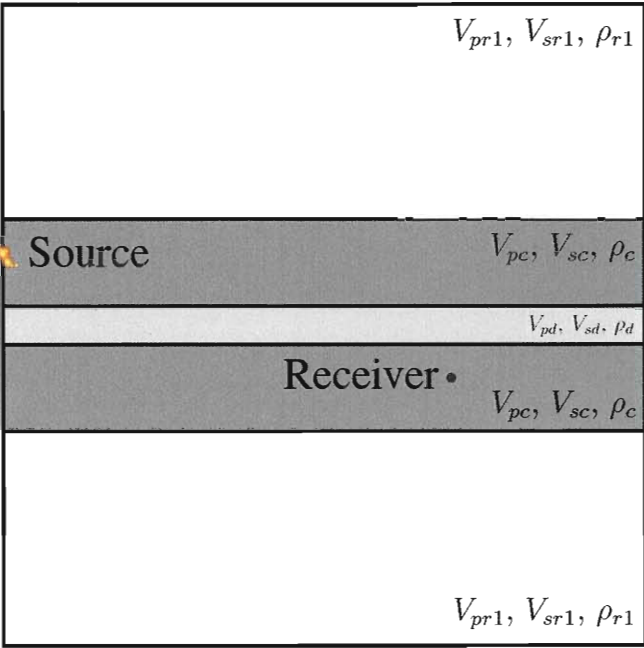

Figure A.3: Layerstack model for embedded dirtband coal seam sequence.

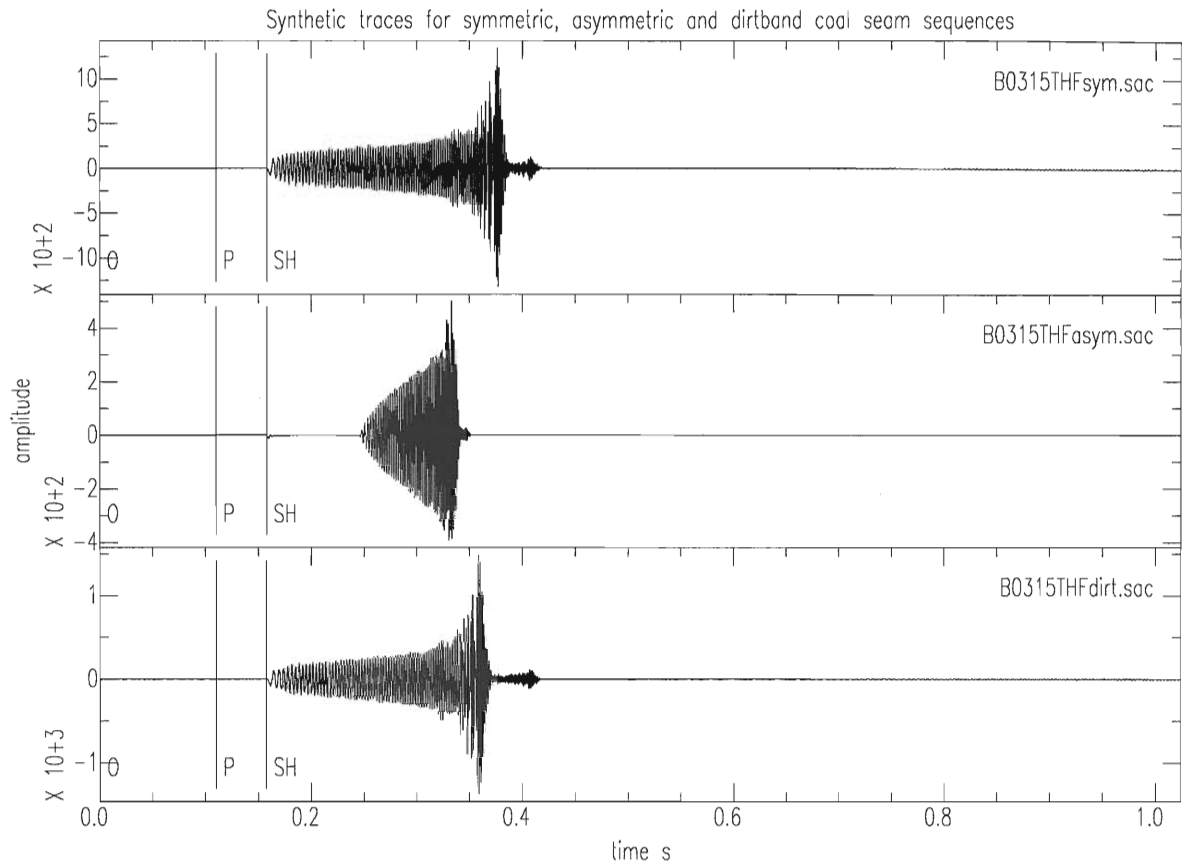

Figure A.4: Synthetic traces for symmetric (top), asymmetric (middle) and embedded dirtband coal seam sequences (bottom).



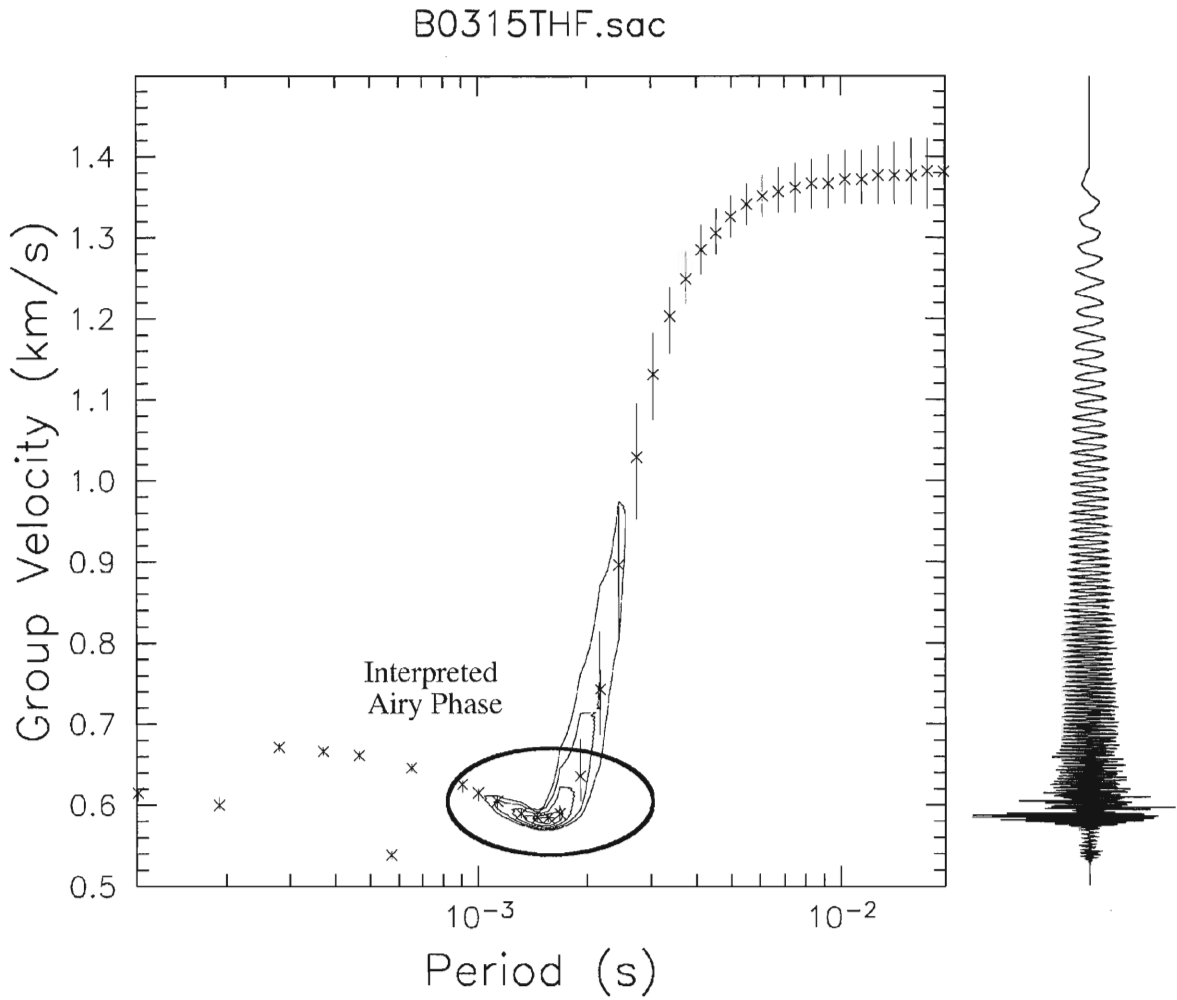

Figure A.5: Dispersion Analysis of synthetic trace for symmetric coal seam sequence. Contours indicate the top 20 % of amplitude values.

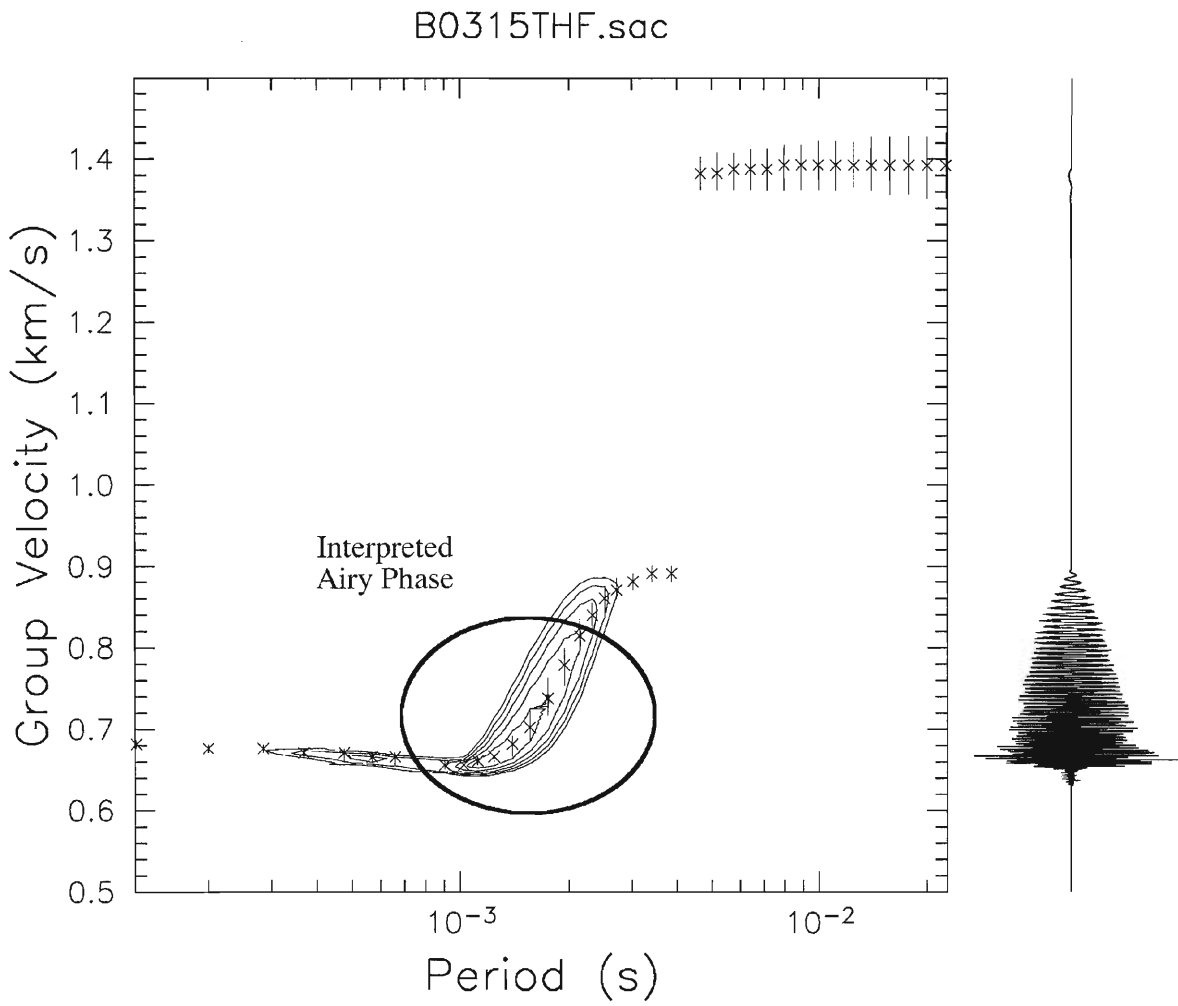

Figure A.6: Dispersion Analysis of synthetic trace for asymmetric coal seam sequence. Contours indicate the top 20 % of amplitude values.

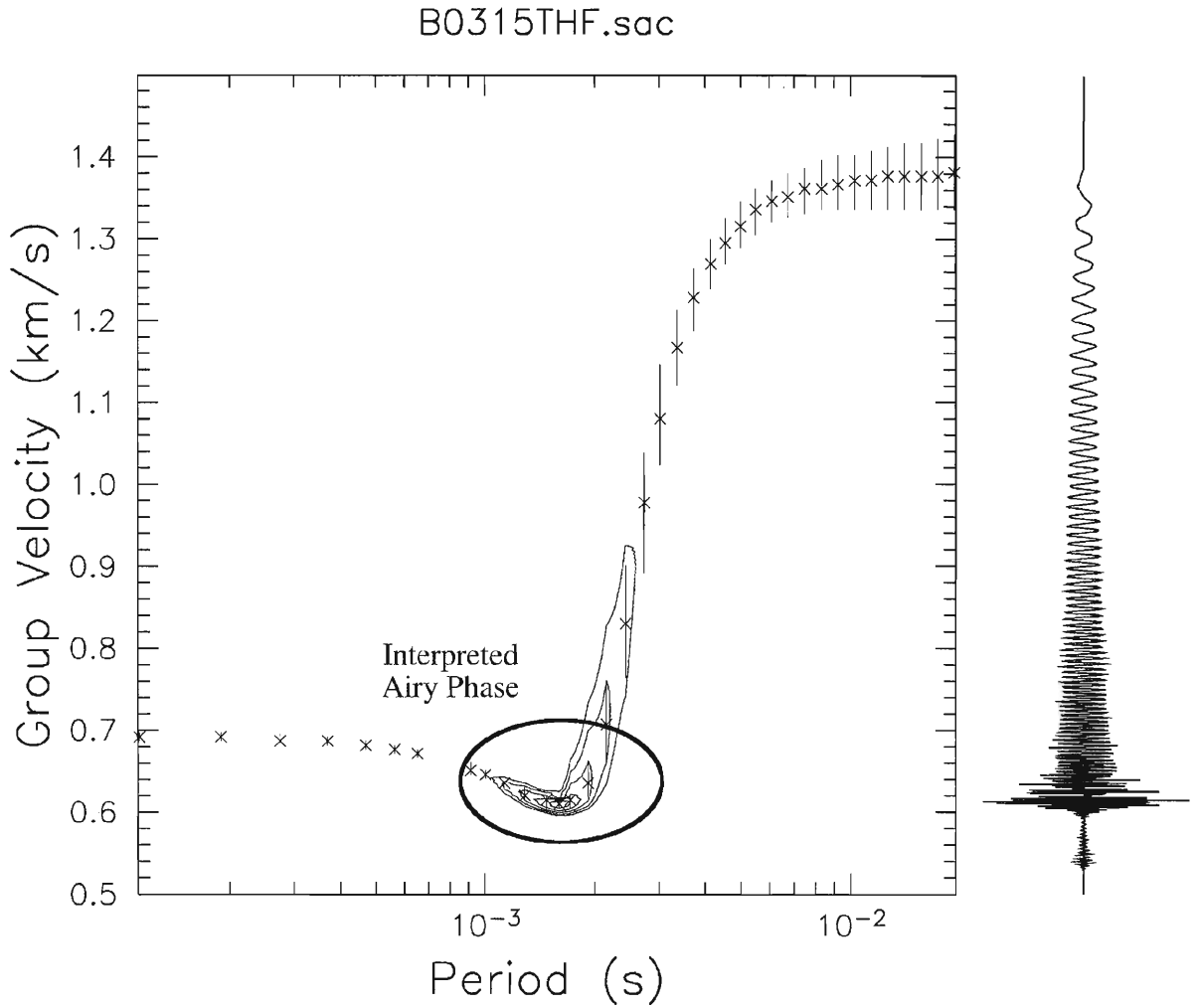

Figure A.7: Dispersion Analysis of synthetic trace for embedded dirt band coal seam sequence. Contours indicate the top 20 % of amplitude values.

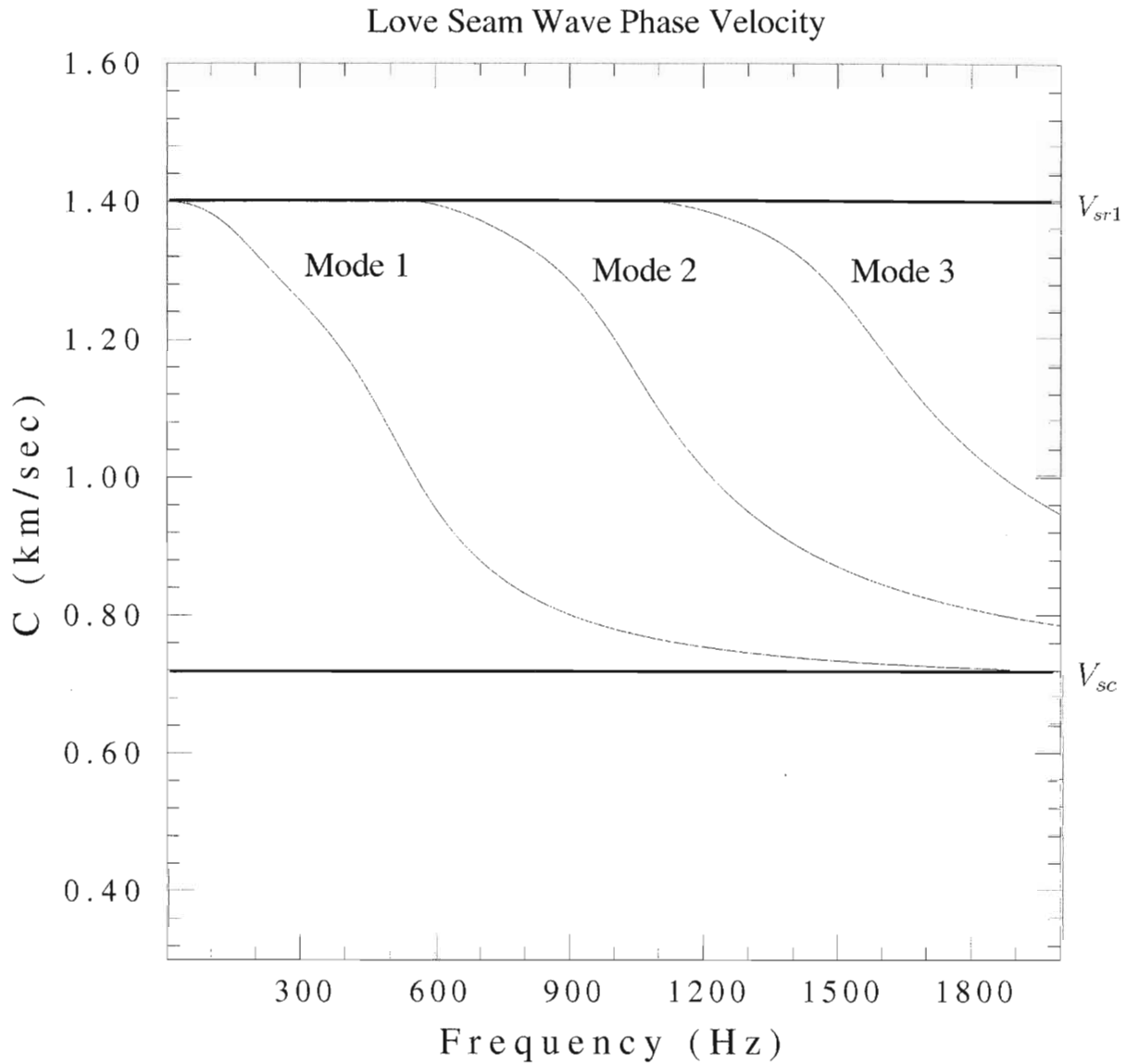

Figure A.8: Analytical solution for the Love type seam wave phase velocity for first three modes. Phase velocities are bound between shear wave velocities of the coal ( $V_{sc}$ ) and surrounding rock ( $V_{sr1}$ ) (dark horizontal lines shown in plot).

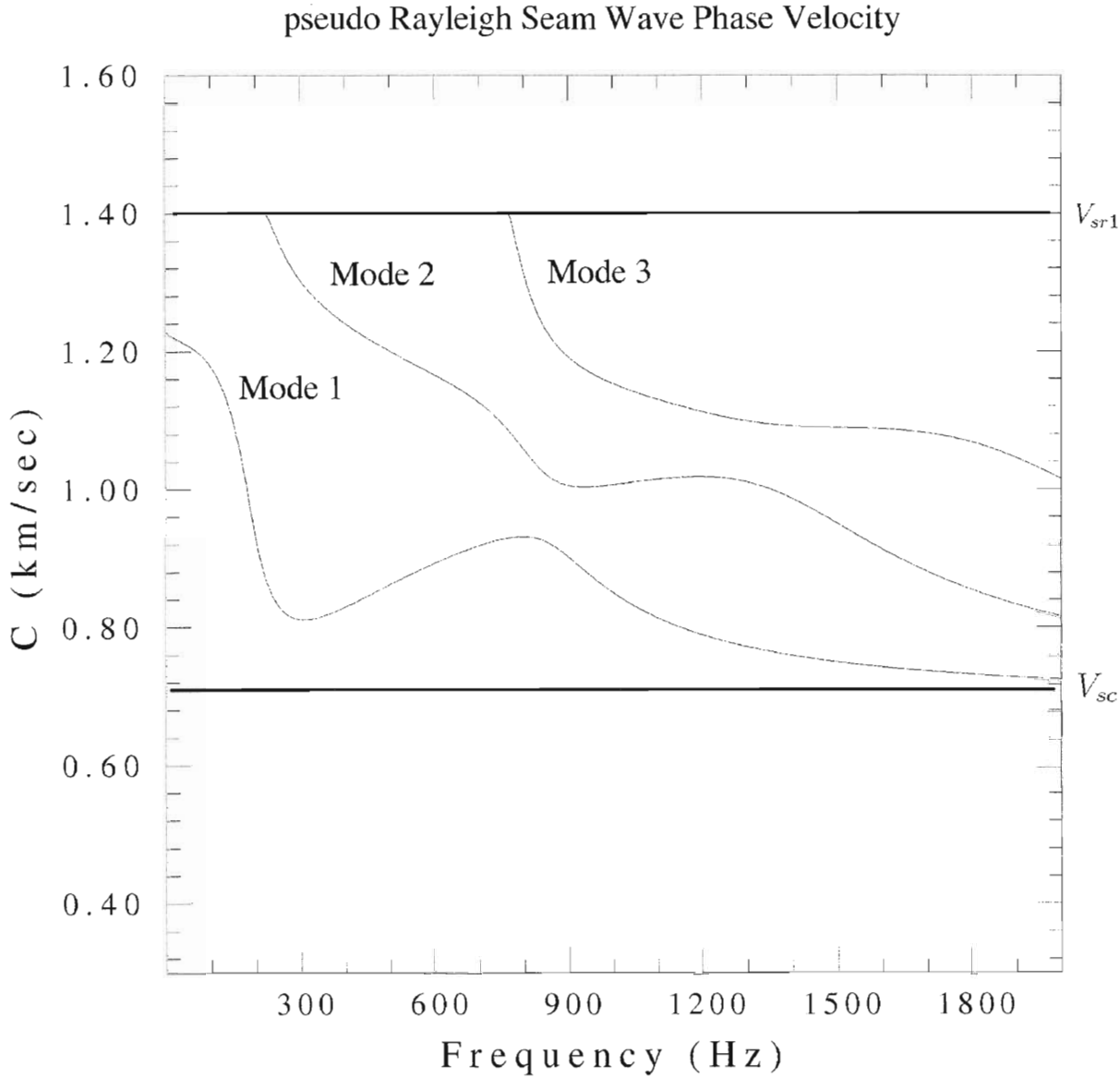

Figure A.9: Analytical solution for the pseudo-Rayleigh type seam wave phase velocity for first three modes. Phase velocities are bound between shear wave velocities of the coal ( $V_{sc}$ ) and surrounding rock ( $V_{sr1}$ )(dark horizontal lines).

### Love Seam Wave Group Velocity

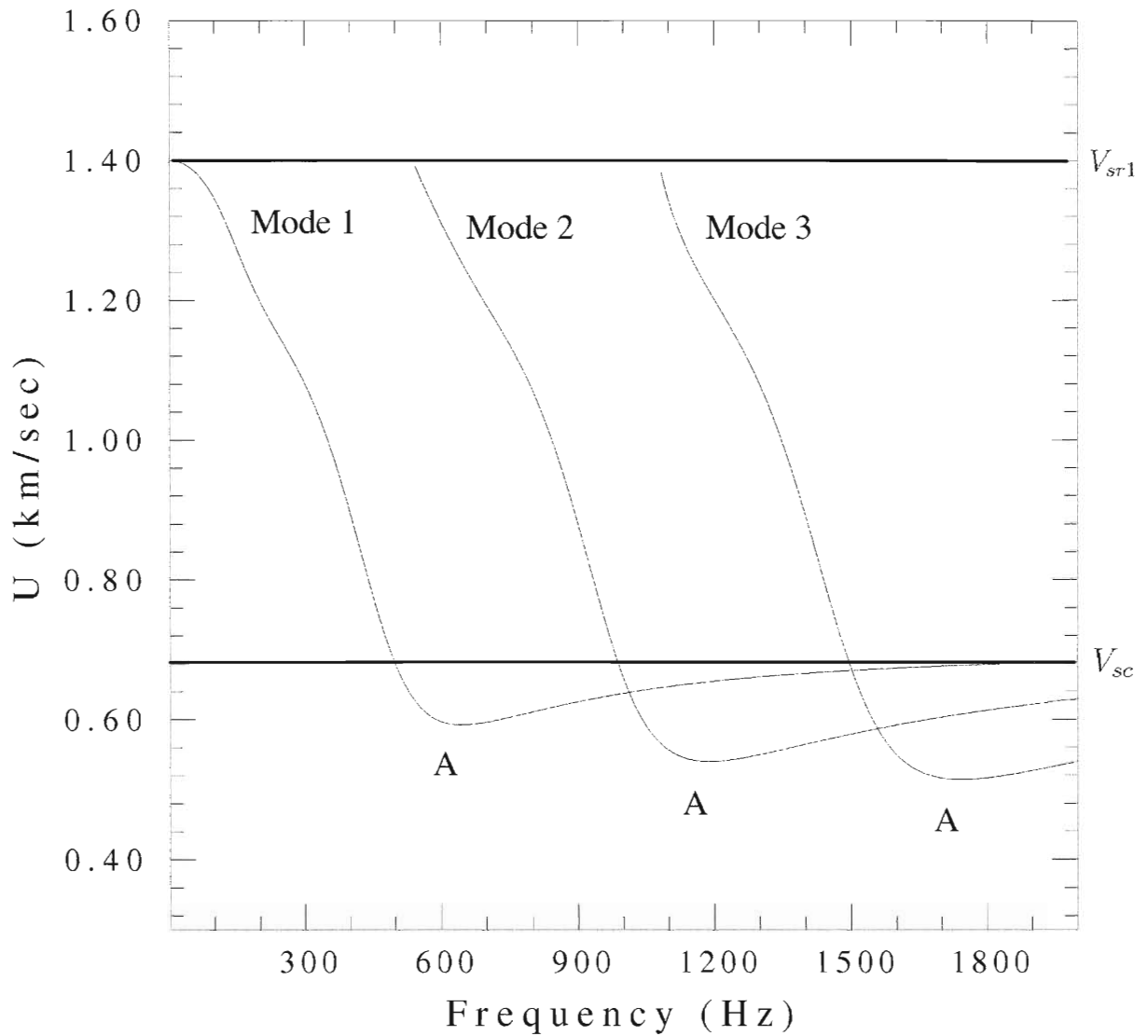

Figure A.10: Analytical solution for the Love type seam wave group velocity for first three modes with interpreted Airy phases.

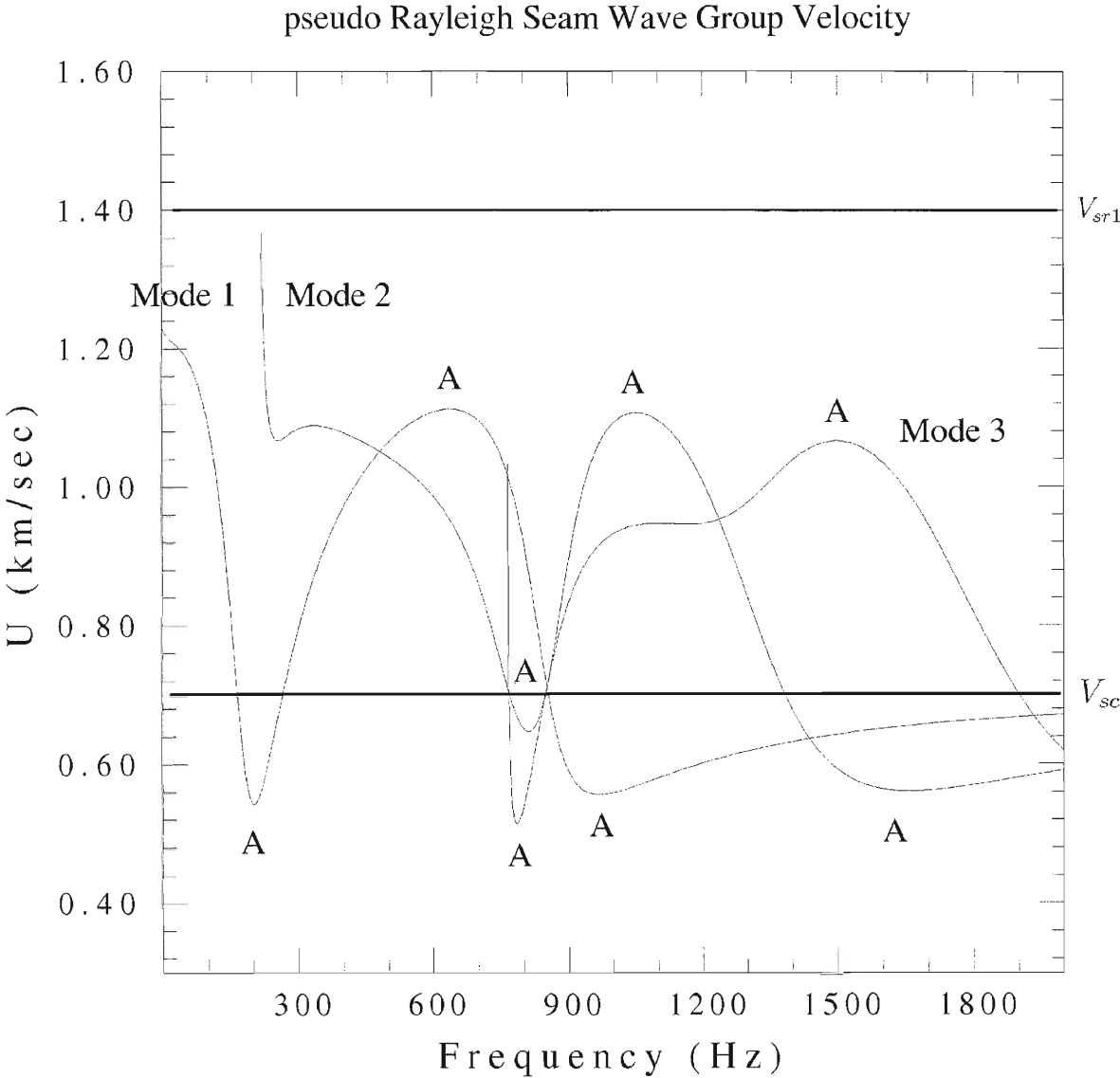

Figure A.11: Analytical solution for the pseudo-Rayleigh seam wave group velocity for first three modes with interpreted Airy phases.

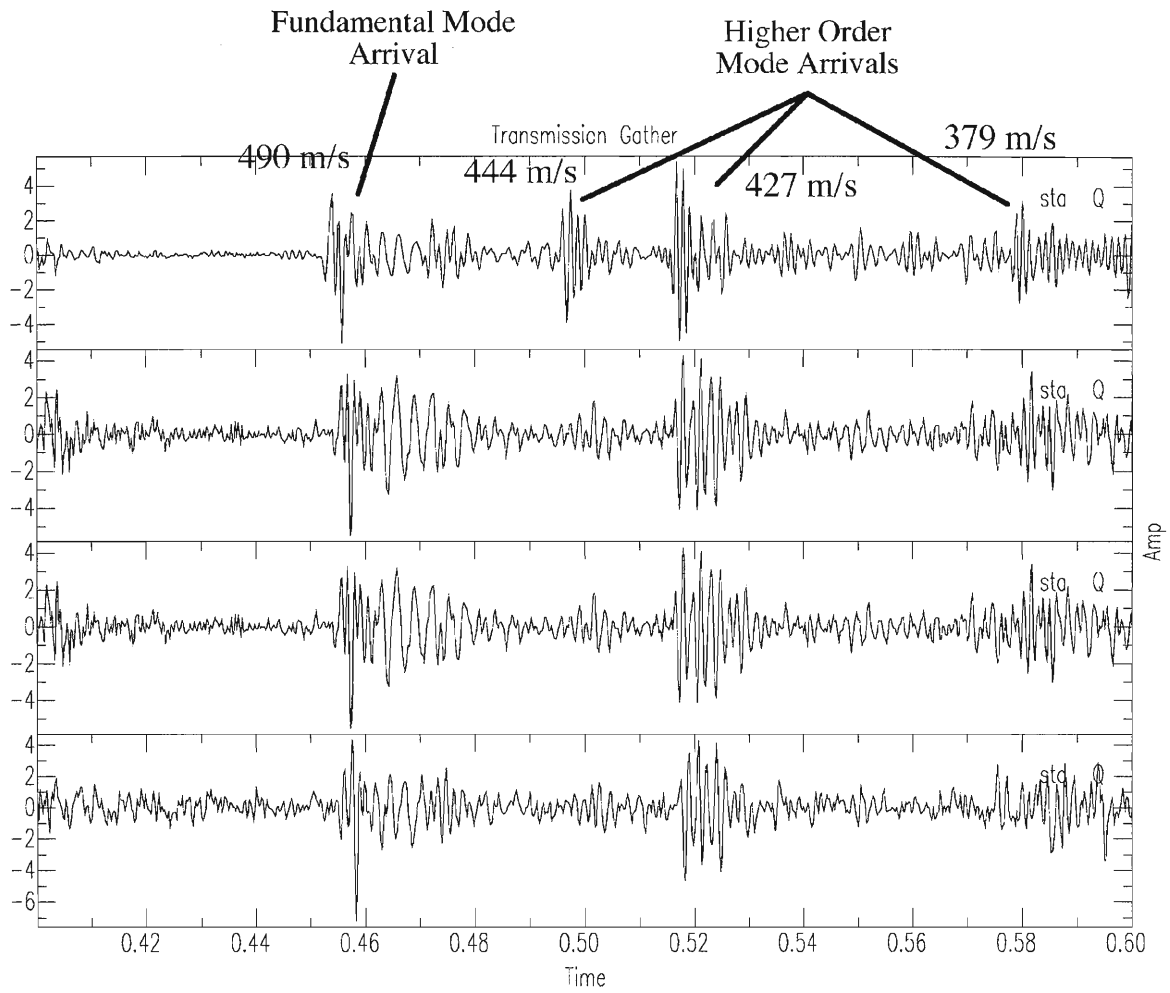

Figure A.12: Recorded data from transmission survey of the Splashdam seam at Hurley, VA



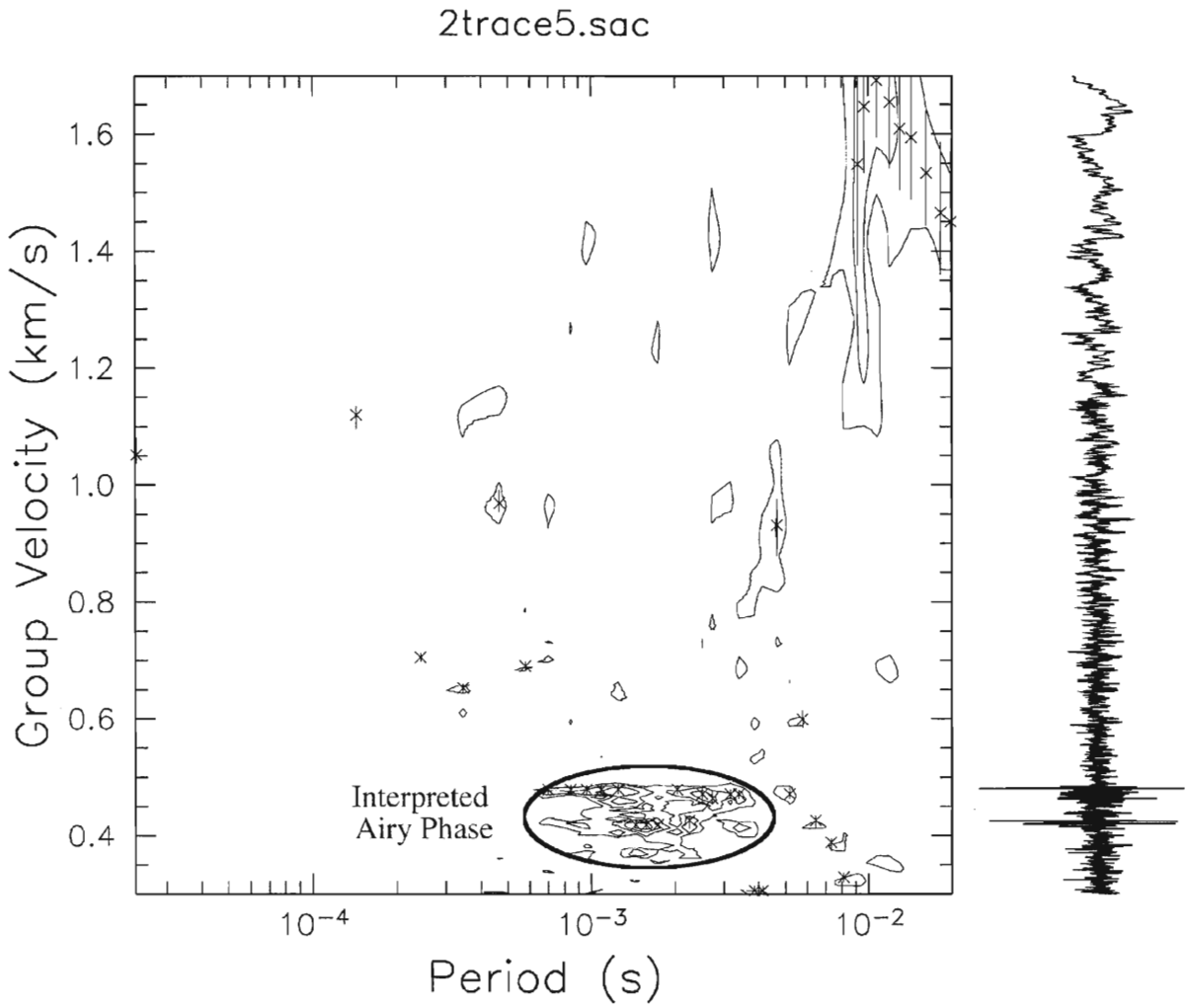

Figure A.13: Dispersion Analysis of record data at Hurley, VA. Contours indicate the highest 20 % amplitudes.

# John E. Feddock, P.E.

## Education:

Graduate Courses - Finance

Case Western Reserve University,  
Cleveland, Ohio, 1975 - 1976

Master of Science - Mining Engineering (Mineral Economics, Rock Mechanics)

Columbia University, Henry Krumb School of Mines,  
New York, New York, 1972

Bachelor of Science - Mechanical Engineering

Columbia University, School of Engineering and Applied Science,  
New York, New York 1969

## Background:

2001 - Present     Senior Vice President  
Marshall Miller & Associates, Lexington, Kentucky

1998 - 2001        Senior Vice President

1996 - 1998        Vice President - Mining and Minerals  
Marshall Miller & Associates, Bluefield, Virginia

1989 - 1996        Vice President - Mining  
L.A. Gates Company, Beckley, West Virginia

1988 - 1989        President  
Feddock Engineering Company, Lexington, Kentucky

1986 - 1988        Vice President - Engineering, Geology and Properties  
Island Creek Corporation, Lexington, Kentucky

1982 - 1986        Chief Engineer  
Rochester & Pittsburgh Coal Company, Indiana, Pennsylvania

1979 - 1982        Fuel Supply Manager  
Keystone Conemaugh Project, Indiana, Pennsylvania

1976 - 1979        Senior Mining Engineer  
GPU Service Corporation, Reading, Pennsylvania

1973 - 1976        Maintenance Superintendent and Project Engineer  
Morton Salt Company, Painesville, Ohio

1972 - 1973        Mine Engineer  
Bethlehem Mines Corporation, Ebensburg, Pennsylvania

1971 - 1972        Research Assistant  
Krumb School of Mines, Columbia University, New York, New York

1969 - 1970        Tunnel Engineer  
Poirier McLane Raymond DiMenna Joint Venture, New York, New York



### **Certifications:**

Registered Professional Engineer, Illinois, Certification No. 062-045536  
Registered Professional Engineer, Kentucky, Certification No. 15248  
Registered Professional Engineer, Ohio, Certification No. 38974  
Registered Professional Engineer, Pennsylvania, Certification No. 024352  
Registered Professional Engineer, Utah, Certification No. 368993  
Registered Professional Engineer, Virginia, Certification No. 034257  
Registered Professional Engineer, West Virginia, Certification No. 10391  
Registered Professional Surveyor, West Virginia, Certification No. 1015  
Certified MSHA Trainer  
MSHA 8 Hour Annual Refresher  
SME Registered Founding Member (Competent Person for Mineral Reserve Estimation)

### **Memberships:**

Society for Mining, Metallurgy and Exploration (SME) of AIME  
Central Appalachian Section of SME  
American Society of Mechanical Engineers

### **Professional Experience:**

1996 - Present     Consultant specializing in Mineral Due-Diligence, Management of mineral companies including bankruptcy, Financial Analysis, Valuation, Mine Design, Expert Witness Testimony, Attorney Technical Support, Equipment Application and Insurance Claim Analysis. Responsible for direction, coordination, scheduling, and review of engineering projects investigated by staff engineers and consultants in the mineral and construction industries. Principal Engineer responsible for due-diligence reviews of both underground and surface mines and mining related facilities, business valuations, financial analysis of mining operations, and Balance Sheet valuation of reserves, mining property, plants and equipment. Primary Consultant providing expert witness testimony, attorney technical support, and insurance claim analysis, specific cases involve: longwall mining, blasting, subsidence, groundwater impacts, lost coal claims, personal injury, production capability, coal contracting, and other mining engineering issues. Recent projects include Valuation of reserves and mines in Kentucky, Colorado, West Virginia, and Virginia, longwall equipment application and performance, surface mine planning and evaluation, coal quality assessment, blasting damage risk, equipment entrapment damage assessment and recovery, business interruption losses, and operations analysis. Experience spans coal mining, quarry operations, tunnel and shaft construction, property management, geo-technical and rock mechanics studies and environmental assessments.

1989 - 1996     Provided mining engineering and technical support to various mining and civil clients. Supervised and managed projects in mine planning, longwall applications, subsidence control, blasting damage, operations analysis, and equipment operation. Involved in over 80 cases where background, experience, and knowledge had been used to evaluate mining impacts on property, equipment, and safety. Prepared background reports, assisted in depositions, been deposed, and testified as an expert. Prepared affidavits and declarations on behalf of clients and provided expert technical support.

### **Professional Experience (Cont.):**

- 1988 - 1989 Provided mining engineering and expert technical support to mining events on reserve acquisition and operations analysis. The firm was dedicated to implementing Quality in mining engineering, production, and management.
- 1986 - 1988 Directed all engineering services including property acquisition and disposal, at all divisions and corporate headquarters for this major coal company, which produced in excess of 20 million TPY. Managed the engineering department with as many as 170 persons and an annual budget in excess of \$10 million.
- 1986 – 1988 Supervised property and coal reserve evaluations, disposals, and acquisitions. Settled several trespass issues including two that were in arbitration. Approved contract operators selected for deep and surface mining and participated as primary corporate officer in three major divestitures of coal reserves and plant facilities. Supervised negotiations with major coal property holding companies in Virginia, West Virginia, and Kentucky.
- Directed the economic justification, planning, contracting, and completion of over \$50 million per year of construction and equipment expenditures. Construction projects included several shafts, buildings, silos, material handling, and preparation plant facilities.
- Supervised the development of a longwall subsidence monitoring program including vibration monitoring, settlement prediction and damage assessment and reparation administration. Directed a longwall performance evaluation of six company mines and coordinated a long term, comprehensive program of longwall system replacement and equipment rebuild.
- Coordinated a comprehensive coal quality forecasting program incorporating statistical process control of mine production with company laboratory operation.
- 1982 - 1986 Directed all engineering services, including geology and private property damage assessment, at all divisions and corporate headquarters for this major coal company which produced in excess of 9 million TPY. Managed the engineering department with 110 persons and an annual budget in excess of \$5 million.
- Developed surface mine engineering and environmental departments within the company to give timely response to repermitting and environmental compliance under Pennsylvania's Primacy of the Surface Mine Control and Reclamation Act of 1977 (SMCRA). As a member of the Environmental Committee of the Keystone Coal Association and the AMC Subsidence Workgroup, participated in public forums and testimony regarding the impact of various Federal and State legislation upon the mining industry.
- 1979 - 1982 Administered coal supply agreements with a value of US \$240 million between utility owners and captive coal suppliers. As a member of a four person administrative team, acted as liaison between a consortium of ten utilities and the operation of two 1800 MW coal-fired generating stations which burn an aggregate eight million TPY. Reviewed and approved annual capital and expense budgets and mining plans of captive suppliers' underground mines. Coordinated consultant inspections, evaluations, and reports.

### **Professional Experience (Cont.):**

- 1979 – 1982 Instituted and coordinated the development of a linear, stochastic program computer model to select the most economical coal supplies for a generating station over a 35-year period. The model incorporated alternative sources of supply (short, intermediate, and long term), coal price forecasts, market constraints, station operating parameters and material handling constraints. A detailed report on the coal supply strategy was accepted and based on the technical and economic evaluations, several long term agreements were renegotiated.
- 1976 - 1979 Supervised utility funded coal exploration programs and technical evaluations of coal mines, dedicated reserves, and coal supply and utilization problems for three wholly owned electric utilities, which burned 16 million TPY. Provided technical expertise and developed numerous interactive language computer programs to evaluate coal preparation schemes, coal mining problems, coal sampling and environmental regulations. A coal cleaning versus FGD strategy was developed.
- Chaired an interutility Task Force to select and develop coal supplies for an innovative technology cleaning plant as an alternative to scrubbing. Evaluated the reliability of supply and coal preparation characteristics of several coal producers to generate a purchasing philosophy for a multi-unit, jointly owned 1850 MW generating station complex which burned five million TPY.
- 1973 - 1976 Supervised a 60-person Maintenance Department for a 1.15 million TPY rock salt mining and milling operation. Instituted preventive maintenance programs and a satellite maintenance area. As Project Engineer, design, acquisition, installation and economic justification of modifications and additions to the plant and mine facility.
- 1972 - 1973 Performed the duties of a Mine Engineer at the Revloc, No. 32 Mine and at the Division Office where responsibilities concentrated on the economic and financial analysis of mining projects.
- 1971 - 1972 Participated in Rock Mechanic Studies at an iron ore mine in eastern Pennsylvania.

### **Publications and Presentations:**

- “Retreat Mining Practices,” Kentucky Professional Engineers in Mining Seminar, Lexington, KY, coauthored with Jinrong Ma, Ph.D., August 2006
- “Safety: A Review and Evaluation of Current Retreat Mining Practices in Kentucky,” 25<sup>th</sup> International Conference on Ground Control in Mining, Morgantown, WV, coauthored with Jinrong Ma, Ph.D., August 2006
- “Retreat Mining Practices in Kentucky,” Environmental and Public Protection Cabinet, Kentucky Department for Natural Resources, Frankfort KY, February, 2006.
- “The Unique Nature of Mineral Property Appraisal”, American Society of Appraisers, Kentucky Chapter Meeting, Louisville KY, June, 2004.
- “Economic Benefits of Coal-based Synthetic Fuel – 1997-2007”, Private presentation for Headwaters, Inc, Lexington, KY, May, 2004.

### **Publications and Presentations (Cont.):**

- “Economic Benefits of Coal-based Synthetic Fuel • 1998-2007 Produced under Section 29 of the Internal Revenue Code, As promulgated through the Oil Windfall Profits Tax Act of 1980,” coauthored with Justin S. Douthat, P.E., December 2003.
- “Valuation of Minerals in Condemnation Proceedings Hypothetical Application of Valuation Methods,” Conference of Government Mining Attorneys (COGMA), Knoxville, TN, September 2003.
- “Determination of Rock Strength Properties Using Geophysical and Ultrasonic Logging in Exploration Drill Holes,” International Conference on Ground Control in Mining, Morgantown, WV, August 2003.
- “Haul Roads” – Chapter 10, SME Mining Reference Handbook, Lowrie, Raymond L., P.E., Editor, Society for Mining, Metallurgy, and Exploration, Inc., Littleton, CO, 2002.
- “Permitting of New Mining Operations, Problems & Possibilities” Electric Power Research Institute – Coal Markets Workshop, Hilton Washington Dulles Airport, Herndon, Virginia, June 2002.
- “Engineering Aspects of Synfuel Projects” coauthored with Justin S. Douthat, P.E. at the Central Appalachian Section of the Society of Mining Engineers of the American Institute of Mining, Metallurgy and Exploration (CAS/SME/AIME) Spring Meeting, Marriott Griffin Gate Resort, Lexington, Kentucky, April 2001.
- “Subsidence and Groundwater Impacts”, Central Appalachian Section of the Society of Mining Engineers of the American Institute of Mining, Metallurgy and Exploration (CAS/SME/AIME) Spring Meeting, Martha Washington Inn, Abingdon, VA, June 2000.
- “Permitting and the Haden Decision” Energy and Mineral Law Foundation Workshop, Ft. Myers Beach, Florida February 2000.
- “Subsidence and Ground Water” June 10, 1999, Abingdon, Virginia, presented at the Central Appalachian Section of the Society of Mining Engineers Conference, co-author Ronald Mullenex C.P.G.
- “Due Diligence: Reserve Assessment and Engineering Considerations,” March 1, 1999, St. Pete Beach Florida, presented at the Financial Times Energy/Coal Outlook Conference, co-authors Marshall S. Miller and K. Scott Keim.
- “Engineering Aspects of Mountaintop Surface Mining,” The 1998 Bluefield Coal Rally sponsored by the Greater Bluefield Chamber of Commerce, Panel Discussion of Mountaintop Mining, Fincastle Country Club, Bluefield, Virginia, October 1998.
- “Mine Planning and Production Costs for MTR and Non-MTR Mining,” Economic Committee of the Governor’s Task Force on Mountaintop Removal and Related Mining Methods, Marshall University Graduate Center, Charleston, West Virginia, October 1998.
- “Practical Applications of Geology and Insurance in Recovering Longwalls,” Longwall USA International Conference, D.L. Lawrence Convention Center, Pittsburgh, Pennsylvania, June 1998.

### **Publications and Presentations (Cont.):**

- “Longwalls in Peril – The Roles of Geology and Insurance,” CAS/SME-WVCMI Joint Meeting, The Greenbrier, White Sulfur Springs, West Virginia, October 1997.
- “Coal Mining: Development, Operations and Management,” Special Institute on Mining and Environmental Law for Trust Officers and Land Managers, Eastern Mineral Law Foundation, Charleston, West Virginia, September 1991.
- “Horizontal Ground Movements and Mining Damage,” Mine Subsidence - Prediction and Control Symposium, Association of Engineering Geologists, 33rd Annual Meeting, Pittsburgh, Pennsylvania, October 1990.
- “Engineering Quality into Surface Mine Planning,” Surface Mining And Reclamation Conference, Charleston, West Virginia, April 1990.
- “PRODUCTIVITY . . . Who is Responsible for Improving It?” Pittsburgh Section - SME Pittsburgh, Pennsylvania, March 1990.
- “Charting a Course Through a Maze of Opportunities,” Career Planning Workshop, Society for Mining, Metallurgy and Exploration (SME), 119th Annual Meeting of AIME, Salt Lake City, Utah, February 1990.
- “Productivity Improvement through Quality Management,” West Virginia Coal Mining Institute of America, White Sulfur Springs, West Virginia, November 1989.
- “PRODUCTIVITY . . . Who is Responsible for Improving It?” Central Appalachian Section of AIME and NICOA Joint Meeting, Lexington, Kentucky, April 1989.
- “Ethics and the State of the Industry,” University of Kentucky Norwood Student Chapter of AIME, Lexington, Kentucky, 1987.
- “Coal and the Environment,” Indiana University of Pennsylvania Business Day IX, Indiana, Pennsylvania, 1986.
- “Compliance with SMCRA in Pennsylvania,” Society of Mining Engineers of AIME Off the Record Meeting, Pittsburgh, Pennsylvania, 1984.
- “Economics of the Energy Industry,” Armstrong-Indiana County Economic Education Foundation, Indiana, Pennsylvania, 1983.
- “Ground Freezing as Used in the Excavation of a Mixed Face,” with M.T. Wane, SME Fall Meeting, St. Louis, Missouri, 1970.

## C.F. Tod Gresham

### Background:

- 1999 – Present Senior Projects and Facilities Coordinator  
Marshall Miller & Associates, Inc., Lexington, Kentucky
- 1998 – 1999 Sales Manager  
Kato Enterprises, Inc., Lexington, Kentucky
- 1991 – 1998 Sales Engineer  
Workman Developments, Inc., Lexington, Kentucky
- 1975 – 1991 Corporate Manager of Projects  
Island Creek Coal Company, Lexington, Kentucky
- 1965 – 1975 District Distribution Engineer  
Columbia Gas System, Charleston, West Virginia

### Memberships:

- American Welding Society  
American Concrete Institute  
Construction Specifiers Institute  
Kentucky Rural Water Association  
Associated General Contractors  
East Kentucky Coal Preparation Engineers Society  
Aircraft Owners and Pilots Association  
SME – Society of Mining, Metallurgy and Exploration

### Professional Experience:

- 1999 – Present Duties include construction management support, capital construction budgeting, project scheduling, equipment specification, field fabrication, pipeline design, regulatory liaison, facilities layouts, and coordination of specialty service associates.
- 1998 – 1999 Consulted on the operations, design and cost estimating on coal-related projects such as coal loading systems, conveying systems, and storage facilities. Managed the operations of the company. Consultant to several engineering companies on the establishment on gas distribution facilities in several Kentucky municipalities.
- 1991 – 1998 Responsible for the sales activities of the company, which supplies polyethylene piping and equipment to the industrial, commercial, municipal and mining industry. Also responsible for engineering evaluations of mining/industrial equipment and operations.
- 1975 – 1991 Responsible for the cost budgeting, design, administrative functions, scheduling, purchasing, third party contracts and direct supervision of field staff on all major corporate projects. This position required extensive knowledge of construction equipment operation and production level, construction procedures, and state and federal regulations.





### **Professional Experience (Cont.):**

- 1975 – 1991 Directed the construction of all major coal projects for the corporation. Responsible for the coordination of coal, oil combustion research, and new equipment development. Innovated the design and fabrication of a coal/oil burner tip used in the atomization of fuel and air during combustion in boilers and kilns.
- 1975 – 1991 Experience in coal preparation, materials handling (coal, lime, cement and rock), ship and barge dock facilities, and fuel combustion.
- 1965 – 1975 Responsible for the design, cost estimating of gas distribution pipelines, meter/regulation facilities and construction budgeting. Supervised the field installation of gas facilities. Served on the corporation's construction and operations standards policy.

### **Selected Projects and Activities:**

- Providence, Kentucky. Responsible for the construction of mine shaft, elevator, roads, warehouse and office facilities.
- Uniontown, Kentucky. Responsible for the rehabilitation of mine slope and new construction of mine warehouse and bathhouse facilities.
- Vansant, Virginia. Responsible for the construction and installation of new coal preparation circuits in coal preparation plants.
- Jacksonville, Florida. Responsible for the construction of a coal oil mixture slurry fuel plant. Also researched the design of the facility.
- Irvine, California. Coordinated the research efforts in slurry fuels and combustion of coal products.
- Stamford, Connecticut. Prepared conceptual plans and cost estimates for a new ship loading petroleum storage facility.
- Jacksonville, Florida. Prepared conceptual design for ship docking and offloading facilities for Celotex Corporation.
- Palatka, Florida. Managed the construction and testing of coal–oil mixture burning at Georgia Pacific Paper Mill.
- Miami, Florida. Consultant on the evaluation of materials handling equipment for Lone Star Cement.
- Lake City, Florida. Managed the construction and testing of coal–oil mixture burning at Occidental Chemical Plant Facilities.
- Wilmington, North Carolina. Managed the construction and testing of coal–oil mixture burning at Diamond Shamrock Chemical.
- South Korea. Consultant for an engineering company in the design and construction of petroleum burning unit on a paper mill boiler.
- Kingsport, Tennessee. Consultant on the design and cost estimating of a coal handling facility.



### **Selected Projects and Activities (Cont.):**

Lexington, Kentucky. Responsible for the design and construction of several commercial office buildings.

Burnside, Kentucky. Consultant for the design, cost estimating and construction of materials handling of charcoal for Kingford, Company

### **Publications and Presentation:**

“The Commercial Demonstration of Coal–Oil Mixtures in the Industrial market,” Fifth International Coal Utilization Conference, Orlando, Florida, 1991.

“The Commercial Production and Use of Slurry Fuels Mixtures,” Fourth International Coal Utilization Conference, Orlando, Florida, 1990.

“Fuel Oil Combustion, University of Florida Publishing (Co–authored), 1990.

“The Occidental Coal–Oil Mixture Project,” Third International Coal Utilization Conference, Orlando, Florida, 1989.

“Construction Scheduling and Project Management,” University of Kentucky College of Architecture, Guest Instructor, 1979.

### **Continuing Education and Seminars Attended:**

Management and Financial Courses, University of Kentucky, Lexington, Kentucky, 1988 and 1990.

Construction Scheduling Courses, University of Louisville, Louisville, Kentucky, 1989, 1990.

Gas Measurement Short Courses, West Virginia University, Morgantown, West Virginia, 1975, 1976 and 1988.

## **Matthias G. Imhof**

Virginia Polytechnic Institute and State University, Department of Geosciences  
4044 Derring Hall (0420), Blacksburg, VA 24061  
phone: (540) 231-6004, fax: (540) 231-3386  
email: mgi@vt.edu

### **Education**

**MASSACHUSETTS INSTITUTE OF TECHNOLOGY**, Cambridge, MA,  
Ph.D. degree in Earth, Atmospheric, and Planetary Sciences, 1996. Thesis, under Professor M.N. Toksöz, on 'Scattering of Elastic Waves using Non-Orthogonal Expansions'.

**EIDGENÖSSISCHE TECHNISCHE HOCHSCHULE**, Zürich, Switzerland,  
Diploma in Earth Sciences (Geophysics), 1991. Thesis, under Professor S. Müller, on 'A Seismostratigraphic Contribution to the Classification of Gravel Deposits in the Rafzerfeld'.

### **Experience**

**VIRGINIA POLYTECHNIC INSTITUTE AND STATE UNIVERSITY**, Blacksburg, VA  
Assistant Professor of Geophysics, Department of Geosciences. Teaching in Exploration Geophysics. Research on reservoir characterization, scattering theory, numerical wave-propagation, and computational geosciences, August 1998 - present.

**MASSACHUSETTS INSTITUTE OF TECHNOLOGY**, Cambridge, MA  
Research Scientist at the Earth Resources Laboratory. Teaching and Research on strong wave scattering, random media, reservoir and borehole geophysics. Supporting graduate students, research personnel, and industry partners, , September 1996 - July 1998.

### **Active Grants**

Department of Energy, Office of Fossil Energy, 'Seismic Determination of Reservoir Heterogeneity: Application to the Characterization of Heavy Oil Reservoirs', Principal Investigator, with subcontract to J. Castle, Clemson University, and collaboration with Chevron Production Company U.S.A., in total \$652,630 (DOE: \$450,071, costshare: \$202,559) over four years (09/01/00 - 08/31/04).

Lawrence Berkeley National Laboratory (PI: E. L. Majer), 'Development and Validation of the Next Generation Method for Quantifying Naturally Fractured Gas Reservoirs'. Collaborating organizations include: Conoco Inc., Lynn Inc., Schlumberger, Stanford University, and Virginia Tech. The proposal received \$3.5 million from DOE. The subcontract between LBNL and Virginia Tech is for \$99,500 over three and a half years (05/16/00 - 12/31/03).

Marshall Miller & Associates, Technical Assistance Program (university-sponsored consulting) on 'Seismic Characterization of Coal Seams: Phases 1&2', \$35,492 (09/01/03 - 10/15/03).

## **Equipment Grants / Donations**

Virginia Tech, College of Arts and Sciences Millennium Grant, 'Seismic Reservoir Characterization Laboratory', Principal Investigator, \$4,000.

Landmark Graphics Corporation, 'Landmark Graphics Corporation Global University Grant Program' for software (Promax and the entire interpretation suite), maintenance, and support. The grant has been upgraded and has an equivalent value of \$7,096,316.

Sun Microsystems, 'John K. Costain Geophysics Computing Facility: 3D Seismic Imaging and Reservoir Characterization Laboratories'. I requested and received two top-of-the-line Sun Blade 1000 workstations with dual processors and dual monitors, a total value of \$44,053.

BP donated a five year old, parallel supercomputer: SGI Power Challenge XL with 12 processors, 6 GB of memory, and 2 TB of disk space.

## **Pending Proposals**

National Science Foundation, EAR Earthscope, 'Collaborative Research: 3D Seismic Reflection at the SAFOD SITE, Phase I'. S. Kemperer, Stanford University; B. Biondi, Stanford University; J. A. Hole, Virginia Tech; M. G. Imhof, Virginia Tech. Total amount requested from NSF: \$124,317, with VT-share of \$34,559.

## **Teaching**

GEOL 3104 'Elementary Geophysics', 50 students, annually.

GEOL 4174 'Exploration Seismology', 12 students, annually.

GEOL 6104 'Advanced Topics in Geophysics: Petrophysics', 10 students, biyearly.

GEOL 6104 'Advanced Topics in Geophysics: Computational Seismology', 10 students, biyearly.

## **Continued Education**

General Mineral Miner (GMM) Certification, Virginia Department of Mines, Minerals and Energy, 2003.

## **Current Students**

Kris Hassinger, MS, Spring 2004.

Sailendra Mahapatra, PhD, Spring 2004.

Ethan Nowak, PhD, Spring 2004.

## **Former Students**

Reeshidev Bansal, MS, 2003, now at University of Texas at Austin.

Shelley Ellison, MS, 2001, now at ChevronTexaco.

## Professional Activities

Member of the Technical Program Committee for the 72nd Annual Meeting of Society of Exploration Geophysicists, 2002.

Chairman of the Seismic Theory session at the 72nd Annual Meeting of Society of Exploration Geophysicists, 2002.

Member of the Student Sections/Academic Liaison Committee of the Society of Exploration Geophysicists, 2003.

Member of the Research Committee of the Society of Exploration Geophysicists, 2003.

Active participant of the Seismic Un\*x project.

Member American Association of Petroleum Geologists (AAPG), American Geophysical Union (AGU), European Association of Geoscientists and Engineers (EAGE), Gold Prospectors Association of America (GPAA), Society of Exploration Geophysicists (SEG), and Sigma Xi.

## Theses

M. G. Imhof, 'Scattering of Elastic Waves using Non-Orthogonal Expansions', Ph.D. Thesis, Massachusetts Institute of Technology, Cambridge MA, 1996.

M. G. Imhof, 'A Seismostratigraphic Contribution to the Classification of Gravel Deposits in the Rafzerfeld', Diplom, Eidgenössische Technische Hochschule, Switzerland, 1991.

## Publications

B. Evans, M. G. Imhof, and G. Siddiqi, 'Remarks on the Mechanics and Kinetics of Permeability Changes in Rocks', US Geological Survey Open File Report, 94-0228, 1994.

M. G. Imhof, 'Multiple Multipole Expansions for Acoustic Scattering', *Journal of the Acoustical Society of America*, 97(2):754-763, 1995.

M. G. Imhof, 'Scattering of Acoustic and Elastic Waves using a Hybrid Multiple Multipole Expansions - Finite Element Technique', *Journal of the Acoustical Society of America*, 100(3):1325-1338, 1996.

M. G. Imhof, 'Multiple Multipole Expansions for Elastic Scattering', *Journal of the Acoustical Society of America*, 100(5), 2969-2979, 1996.

M. G. Imhof and M. N. Toksöz, 'Acousto-Elastic Multiple Scattering: A Comparison of Ultrasonic Experiments with Multiple Multipole Expansion', *Journal of the Acoustical Society of America*, 101(4), 1836-1846, 1997.

M. G. Imhof, M. N. Toksöz, C. I. Burch, and J. H. Queen, 'Near Surface Scattering from High Velocity Carbonates in West Texas', *Journal of Seismic Exploration*, 8(4), 221-242, 1999.

M. G. Imhof and M. N. Toksöz, 'Calculating Seismic Source Signatures for Explosions in and around Cavities', *Bulletin of the Seismological Society of America*, 90(1), 229-242, 2000.

M. G. Imhof and M. N. Toksöz, 'Estimation of Stratigraphic Heterogeneity using Seismic Reflection Data', *Journal of Seismic Exploration*, 9(1), 2000.

## **Publications (continued)**

M. G. Imhof, 'A Stable Optimal Absorbing Boundary Condition for Acoustic Finite-Difference Modeling', *Journal of Seismic Exploration*, 10, 281-291, 2002.

M. G. Imhof and M. N. Toksöz, 'The Effect of Multiple Cavity Explosions on Seismic Signatures', *Bulletin of the Seismological Society of America*, 92(6), 2381-2390, 2002.

M. G. Imhof, 'Scale Dependence of Reflection and Transmission Coefficients', *Geophysics*, 68(1), 322-336, 2003.

M. G. Imhof and W. C. Kempner, 'Seismic Heterogeneity Cubes and Corresponding Equiprobable Simulations', *Journal of Seismic Exploration*, 12(1), 1-16, 2003.

M. G. Imhof, 'Estimating Reservoir Changes from AVO Changes', *Journal of Seismic Exploration*, 12, 141-150, 2003.

S. J. Ellison, M. G. Imhof, C. Çoruh, D. A. Fuqua, and S. C. Henry, 'Modeling Offset-Dependent Reflectivity for Time-Lapse Monitoring of Water-Flood Production in Thin-Layered Reservoirs', *Geophysics*, in press.

M. G. Imhof, 'Computing the Elastic Scattering from Inclusions Using the Multiple Multipoles Method in 3D', *Geophysical Journal International*, in press.

## **Submitted Publications**

B. J. Carney, J. A. Hole, D. A. Okaya, and M. G. Imhof, 'Building the Steep-Dip Migration Velocity Model through First Arrival Traveltime Tomography', *Geophysics*.

R. Bansal and M. G. Imhof, 'Enhancement of Fracture Signals on Surface Seismic Data', *Geophysics*.

## **Expanded Abstracts with Presentation**

M. G. Imhof and M. N. Toksöz, 'Multiple Multipole Expansions for Acoustic Scattering', 56th Meeting of the European Association of Exploration Geophysicists, Vienna, 1994.

M. G. Imhof, 'Multiple Multipole Expansions for Elastic Scattering', 64th Annual International Meeting of the Society of Exploration Geophysicists, Los Angeles, 1994.

M. G. Imhof and M. N. Toksöz, 'An Approach for Random Media Parameter Estimation using Seismic Reflection Data', The Signal Processing Society of the Institute of Electrical and Electronic Engineers (IEEE), International Conference on Acoustics, Speech, and Signal Processing (ICASSP), Detroit, 1995.

M. G. Imhof, M. N. Toksöz, C. I. Burch, and J. H. Queen, 'Near Surface Scattering from High Velocity Carbonates in West Texas', 59th Meeting of the European Association of Geoscientists & Engineers, Geneva, 1997.

M. G. Imhof and M. N. Toksöz, 'Calculating Seismic Source Signatures for Explosions in and around Cavities', 19th Research Symposium on Monitoring a Comprehensive Test Ban Treaty (CTBT), Orlando, 1997.

## **Expanded Abstracts with Presentation (continued)**

M. G. Imhof and M. N. Toksöz, 'Multiple Multipole Expansions for Acousto-Elastic Multiple Scattering', Proceedings of the 3rd Workshop on Electromagnetic and Light Scattering - Theory and Applications, Bremen, 1998.

M. G. Imhof, 'Scale and Frequency Dependence of Reflection and Transmission Coefficients', 68th Annual International Meeting of the Society of Exploration Geophysicists, New Orleans, 1998.

M. G. Imhof, 'A Stable Optimal Absorbing Boundary Condition for Finite-Difference Modeling', 61th Meeting of the European Association of Geoscientists & Engineers, Helsinki, 1999.

M. G. Imhof, 'Determination of Subsurface Heterogeneity using Reflection Seismic Data', 69th Annual International Meeting of the Society of Exploration Geophysicists, Houston, 1999.

J. A. Hole and M. G. Imhof, 'Resolution Issues in Travel Time Tomography', in A. W. B. Jacob, C. J. Bean, and S. T. F. Jacob, eds., 'Active and Passive Seismic Techniques Reviewed', Proceedings of the 11th Commission on Controlled-Source Seismology Workshop, Communications of the Dublin Institute of Advanced Studies, Series D, Geophysical Bulletin 49, 32-34, 2000.

M. G. Imhof, 'The Heterogeneity Cube: a Family of Seismic Attributes', 71st Annual International Meeting of the Society of Exploration Geophysicists, San Antonio, 2001.

S. Ellison, M. G. Imhof, C. Çoruh, D. A. Fuqua, and S. Henry, 'Modeling offset-dependent reflectivity for time-lapse monitoring of water flood production in thin-layered reservoirs', 71st Annual International Meeting of the Society of Exploration Geophysicists, San Antonio, 2001.

M. G. Imhof, 'The Heterogeneity Cube: a Family of Seismic Attributes', American Association of Petroleum Geologists Annual Convention, Houston, 2002.

M. G. Imhof, 'Estimation of 3D Reservoir Heterogeneity using Seismic Heterogeneity Cubes', 64th Meeting of the European Association of Geoscientists & Engineers, Florence, 2002.

M. G. Imhof, 'Wave-Equation Tomography in Scattering and Reflection Mode', 64th Meeting of the European Association of Geoscientists & Engineers, Florence, 2002.

M. G. Imhof, 'Calculating the Seismic Effect of 3D Underground Structures and Topography with the Finite-Difference Method', 72nd Annual International Meeting of the Society of Exploration Geophysicists, Salt Lake City, 2002.

E. Nowak, M. G. Imhof, and W. Kempner, 'Object-Based Stochastic Facies Inversion: Application to the Characterization of Fluvial Reservoirs', 72nd Annual International Meeting of the Society of Exploration Geophysicists, Salt Lake City, 2002.

R. Bansal, M. G. Imhof, and T. Daly, 'Seismic Detection of Fractures in Tight Gas Sands', 72nd Annual International Meeting of the Society of Exploration Geophysicists, Salt Lake City, 2002.

M. G. Imhof and J. H. Queen, 'Enhancing Seismic Images using Anisotropic Nonlinear Diffusion', 65th Meeting of the European Association of Geoscientists & Engineers, Stavanger, 2003.

## **Expanded Abstracts with Presentation (continued)**

M. G. Imhof, 'Equiprobable Simulations of Seismic Heterogeneity Cubes', 65th Meeting of the European Association of Geoscientists & Engineers, Stavanger, 2003.

M. G. Imhof, 'Computing the Elastic Scattering from Inclusions Using 3D Multiple Multipoles Method', 65th Meeting of the European Association of Geoscientists & Engineers, Stavanger, 2003.

M. G. Imhof, 'Enhancing Seismic Images using Anisotropic Nonlinear Diffusion', 73rd Annual International Meeting of the Society of Exploration Geophysicists, Dallas, 2003.

E. Nowak, M. G. Imhof, and W. Kempner, 'Object-Based Stochastic Facies Inversion', 73rd Annual International Meeting of the Society of Exploration Geophysicists, Dallas, 2003.

E. Nowak and M. G. Imhof, 'Stratigraphic Filtering', 73rd Annual International Meeting of the Society of Exploration Geophysicists, Dallas, 2003.

S. Mahapatra, M. G. Imhof, and W. Kempner, 'Poststack Interpretive Static Correction', 73rd Annual International Meeting of the Society of Exploration Geophysicists, Dallas, 2003.

R. Bansal and M. G. Imhof, 'Discrimination and Enhancement of Fracture Signals on Surface Seismic Data', 73rd Annual International Meeting of the Society of Exploration Geophysicists, Dallas, 2003.

## **Abstracts with Presentation**

M. G. Imhof, 'Wave Scattering Using a Hybrid MMP - FE Technique', 130th Meeting of the Acoustical Society of America, St. Louis, 1995.

M. G. Imhof, 'A Numerical Approach to Scattering by Many Scatterers of Various Sizes', 130th Meeting of the Acoustical Society of America, St. Louis, 1995.

J. A. Hole and M. G. Imhof, 'Irrelevance of the Fresnel Zone in First-Arrival Travel-Time Tomography', Eos, Transactions of the American Geophysical Union, 81, Fall Meeting Supplement F894, 2000.

B. J. Carney, J. A. Hole, D. A. Okaya, and M. G. Imhof, 'Use of First-Arrival Tomography to Build the Velocity Model for Steep-Dip Prestack Depth Migration', Eos, Transactions of the American Geophysical Union, 81, Fall Meeting Supplement F897, 2000.

M. G. Imhof and W. C. Kempner, 'Seismic Heterogeneity Cubes and Corresponding Equiprobable Simulations', American Association of Petroleum Geologists Annual Convention, Salt Lake City, 2003.

S. Mahapatra, M. G. Imhof, and W. C. Kempner, 'Deterministic High-Resolution Seismic Reservoir Characterization', American Association of Petroleum Geologists Annual Convention, Salt Lake City, 2003.

M. G. Imhof, 'Seismic Heterogeneity Cubes and Corresponding Equiprobable Simulations', Interpreting Reservoir Architecture Using Scale-Frequency Phenomena, Oklahoma City, 2003.



## **Abstracts with Presentation (continued)**

J. Piver, J. W. Castle, M. T. Poole, R. A. Hodges, and M. G. Imhof, 'Integrating Geologic Models and Seismic Data to Characterize Interwell Heterogeneity of the Miocene Temblor Formation, Coalinga, California', Geological Society of America Joint Annual Meeting of the South-Central Section (37th) and Southeastern Section (52nd), Memphis, 2003.

M. G. Imhof, 'Quantifying Seismic Heterogeneity', Commission on Controlled-Source Seismology 12th International Workshop, 2003.

M. G. Imhof, 'A Quantitative Stratigraphic Model Based on Nonlinear Anisotropic Diffusion', American Association of Petroleum Geologists Annual Convention, 2004.

M. G. Imhof, 'A First Step Towards Quantitative Seismostratigraphic Inversion', American Association of Petroleum Geologists Annual Convention, 2004.

## Daniel J. Yancey

2600-B Luster's Gate Rd., Blacksburg, VA, 24060, (434) 426-0458, dyancey@vt.edu

### Education

Currently pursuing an M.S. at Virginia Tech in Geophysics. Expected graduation date: Spring 2006

B.S. Geosciences (Magna Cum Laude) Concentration: Geophysics, Minor: Mathematics. May 2004, Virginia Tech. G.P.A. 3.61/4.0.

### Experience

BP Exploration Alaska, Geophysics Intern, Anchorage, AK, Summer 2005.

- Seismic structure mapping of aquifers for waterflood in Prudhoe Bay reservoirs.
- Wavelet extraction techniques for synthetic seismic generation.

Geoscience Intern with Marshall Miller and Associates, Energy and Mineral Resources Group. Bluefield, VA and Kingsport, TN. Summer 2004.

- Consulting work for possible injection locations for Regional Carbon Sequestration Program for Southern States Energy Board.
- Gas evaluations (both conventional and coal-bed methane) for gas companies in VA and WV.

Research Assistant for Dr. John Hole at Virginia Tech. Fall 2003.

- Duties included work for the San Andreas Fault area using ArcView GIS.

### Related Coursework/Experience

Advanced Engineering Mathematics, Advanced Structural Geology, Carbonate Deposystems, Carbonate Diagenesis, Computational Seismology, Continuum Mechanics, Earthquake Seismology, Exploration Seismology, Inverse Theory, Petrophysics, Potential Field Geophysics, Sedimentology-Stratigraphy, Seismic Stratigraphy, Strong Motion Seismology, Structural Geology, Technical Writing, Theoretical Seismology and Wave Propagation.

### Computer Skills

CPS (Computer Programs in Seismology), Jason, Mathematica, Matlab, ProMax, SAC (Seismic Analysis Code), Seismic Un\*x, SeisWorks, Syntool, Z-MAP

### Honors and Activities

Boy Scouts of America, 1987-Present. Earned Eagle Scout Award.

Marathon Oil Scholarship Recipient, Spring 2002

Matthew J. Mikulich Endowed Geophysics Scholarship Recipient, Fall 2002

Conoco-Phillips Fellowship, Fall 2004.

## **Expanded Abstracts with Presentations**

Yancey, D.J., Imhof, M.G., Gresham, T., 2005, Geophysical Mine-Void Detection using In-Seam Seismics: 75th Annual International Meeting, SEG, Expanded Abstracts.

Yancey, D.J., Imhof, M.G., Gresham, T., 2006, Geophysical Mine-Void Demonstration using In-Seam Seismics: 68th Conference and Exhibition, EAGE, Expanded Abstracts. Submitted.